

NOTES: UNLESS OTHERWISE SPECIFIED

- 1. QUADPOD INTERFACES DIRECTLY WITH NEXTMOVE POSITIONERS THAT CONTAIN TYPE-4.000, TYPE-4.000-P, TYPE-4.750 AND TYPE-4.70-P MOUNTING INTERFACE
- 2. HARD COAT ANODIZE ALUMINUM CONSTRUCTION WITH STAINLESS STEEL HARDWARE
- 3. WEIGHT APPROXIMATELY 60 LBS (27.2 kg). DOES NOT INCLUDE POSITIONER MOUNTING HARDWARE (NOT SHOWN)
- 4. PAYLOAD NOT TO EXCEED 750 LB (340.2 kg)
- 5. CENTER OF GRAVITY OF POSITIONER AND PAYLOAD MUST NOT EXCEED DIAMETER DIMENSION SHOWN TO PREVENT TIPPING. STAKE DOWN OR USE SAND BAGS ON TRIPOD LEGS TO ENSURE STABILITY

- 6. INDICATED DIMENSION SHOWS DEPLOYED HEIGHT OF QUADPOD WITH THREADED LEVELING LEGS AT MINIMUM SETTING
- 7. THREADED LEVELING LEGS HAVE APPROXIMATELY 1 INCH OF ADJUSTABILITY AND CAN BE ADJUSTED WITH USE OF A 7/16 INCH WRENCH OR SOCKET
- 9. WHEN IN THE DEPLOYED ORIENTATION, ENSURE THREADED KNOBS ARE TIGHTENED ADEQUATELY AND ANGLED STRUTS ARE IN DETENTED POSITION SHOWN
- 10. POSITIONER HARDWARE MOUNTING KITS ARE INCLUDED (NOT SHOWN)

- 11. QUADPOD COMES STANDARD WITH ONE RISER ASSEMBLY AS SHOWN THROUGHOUT DRAWING. ADDITIONAL RISER ASSEMBLY, PART NUMBER ACC-N901491-20, CAN BE PURCHASED SEPARATELY TO ADD 20 INCHES OF HEIGHT TO THE QUADPOD
- 12. INDICATED SLOT FEATURES TO BE USED FOR OPTIONAL TIE DOWN STRAP KIT, PART NUMBER ACC-N901495-1
- 13. ADJUST INDICATED MAST LEVELING LEG TO ENSURE SOLID CONTACT AND WEIGHT TRANSFER TO GROUND
- 14. SEE SHEETS 5 THRU 9 FOR ASSEMBLY INSTRUCTIONS

REV	DESCRIPTION	DATE	APPROVED
B	CN601344	2024-02-08	SRC

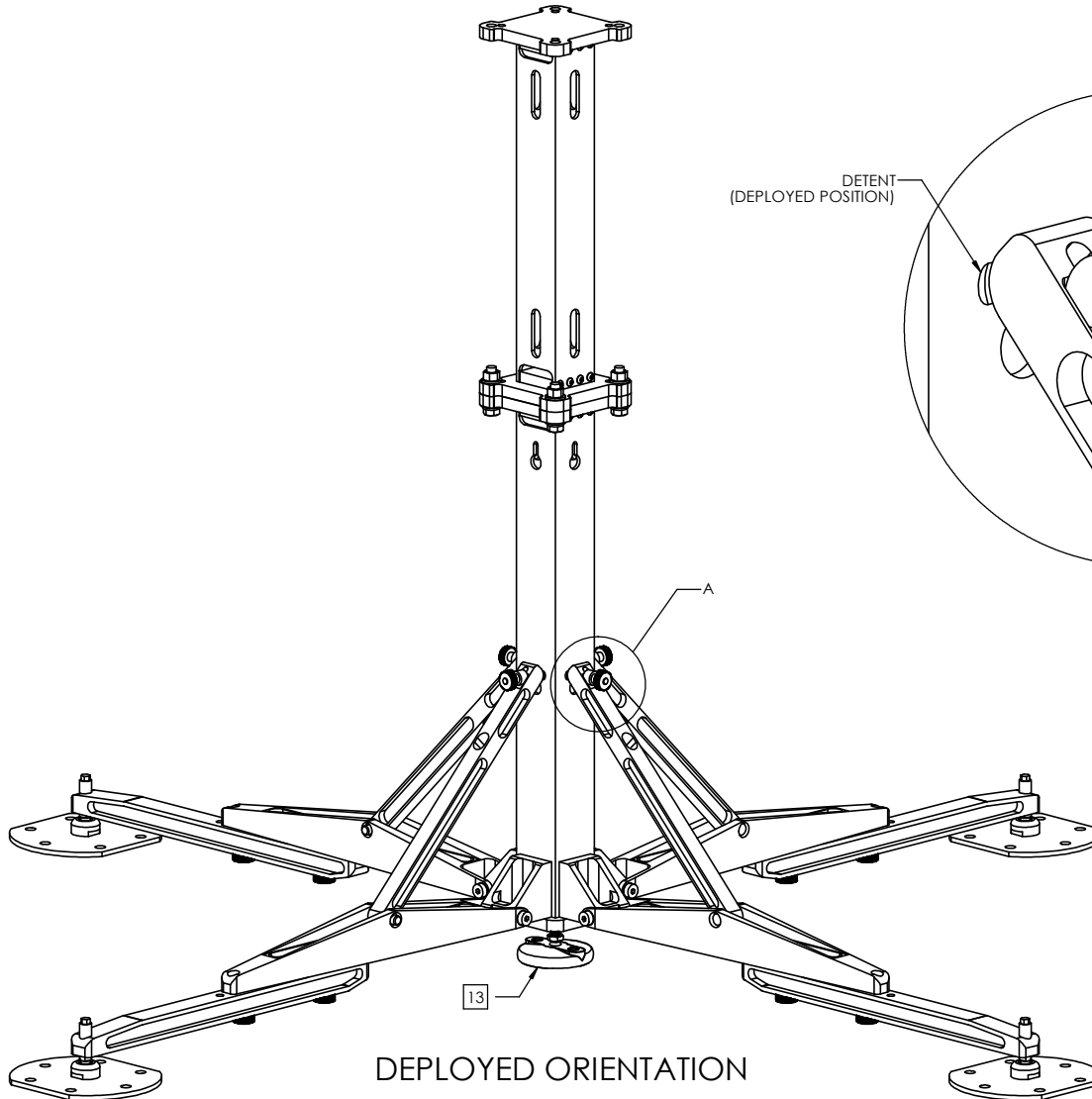

DEPLOYED ORIENTATION

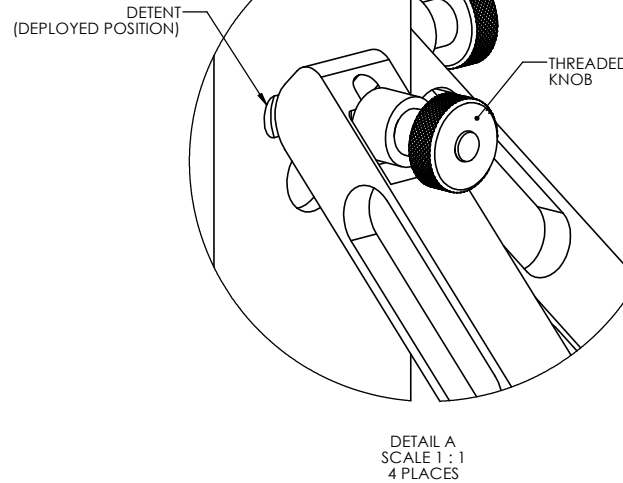

DETAIL A
SCALE 1 : 1
4 PLACES

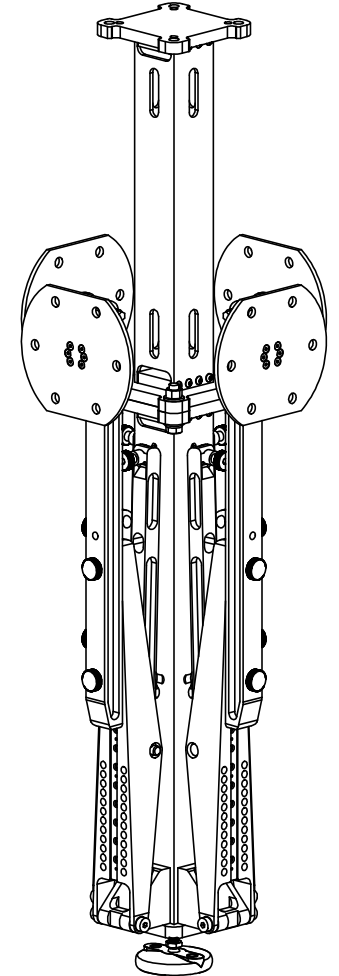

STOWED ORIENTATION

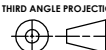
SYMBOL KEY <input type="checkbox"/> NOTE <input type="checkbox"/> PL ITEMS PROPRIETARY AND CONFIDENTIAL THE INFORMATION CONTAINED IN THIS DRAWING IS THE SOLE PROPERTY OF QPAR ANTENNAS USA, LLC. ANY REPRODUCTION IN PART OR AS A WHOLE WITHOUT THE WRITTEN PERMISSION OF NEXTMOVE TECHNOLOGIES IS PROHIBITED. QPAR ANTENNAS USA, LLC EL CAJON, CA 2020 www.qparusa.com	UNLESS OTHERWISE SPECIFIED: DIMENSIONS ARE IN INCHES TOLERANCES: ANGLE ± 5 DEGREES TWO PLACE DECIMAL ± 0.00 THREE PLACE DECIMAL ± 0.010 INTERPRET DIM AND TOL PER ASME Y14.5M - 1994	DRAWN: S. CHEYNE 2023-10-02 CHECKED: C. CHEYNE 2023-10-05 A/E APPR.: S. CHEYNE 2023-10-02 E/E APPR.: 2023-10-05	QPAR Antennas USA, LLC TITLE: INTERFACE CONTROL DRAWING, EXTENDED HEAVY DUTY QUADPOD	
	THIRD ANGLE PROJECTION  DO NOT SCALE DRAWING	PART NO. ACC-N901492-1	SIZE: DWG. NO. C ICDN901492	REV B
	SCALE: 1:5		SHEET 1 OF 9	
	QPAR ANTENNAS USA, LLC			

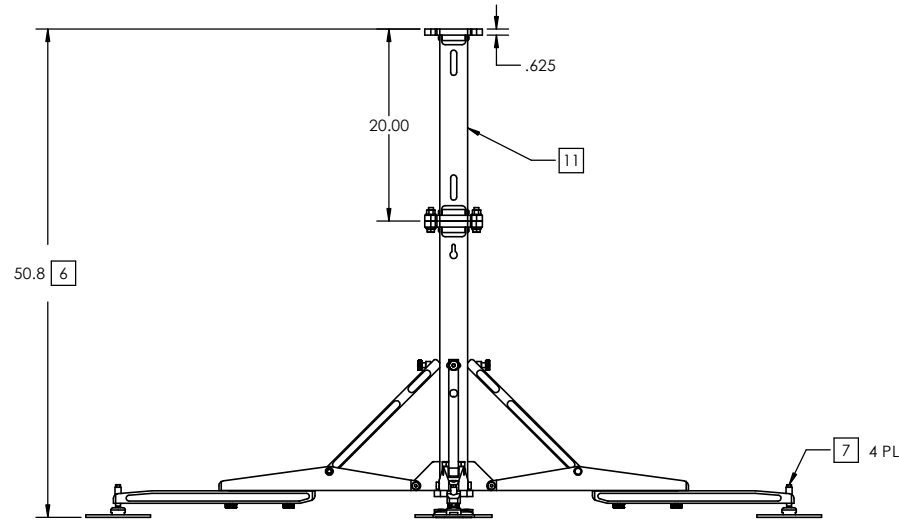
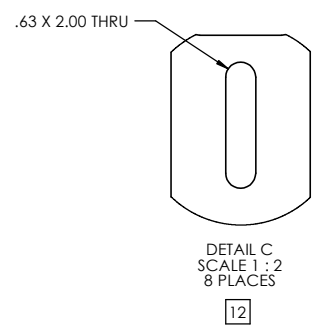
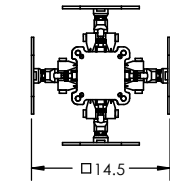
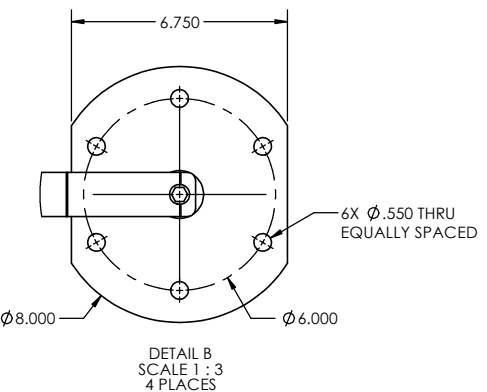
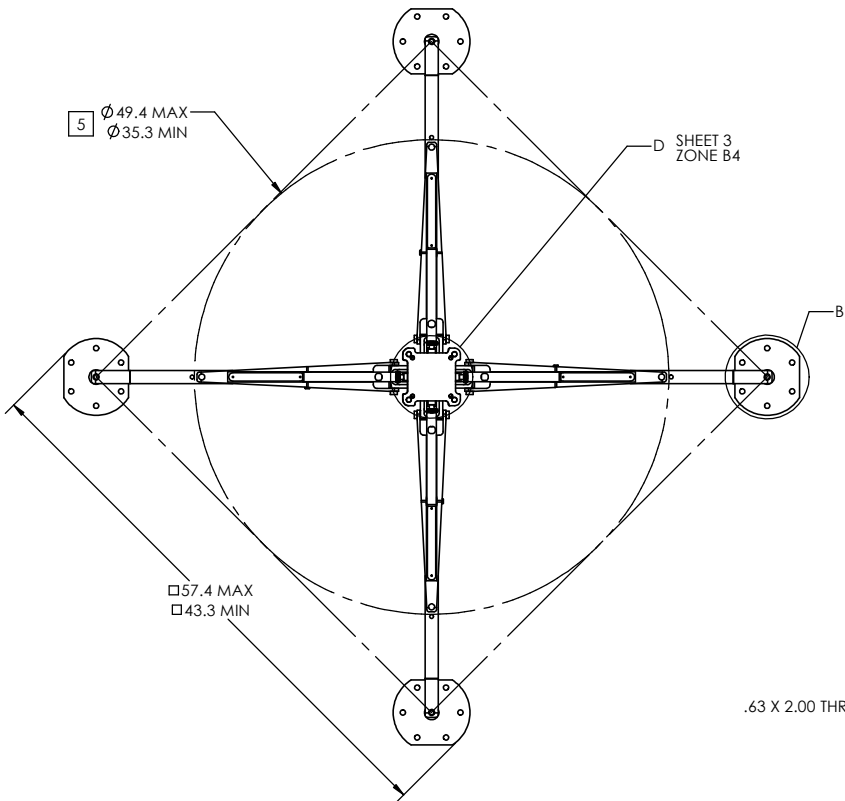

DEPLOYED ORIENTATION

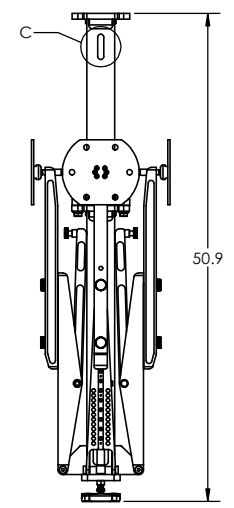

STOWED ORIENTATION

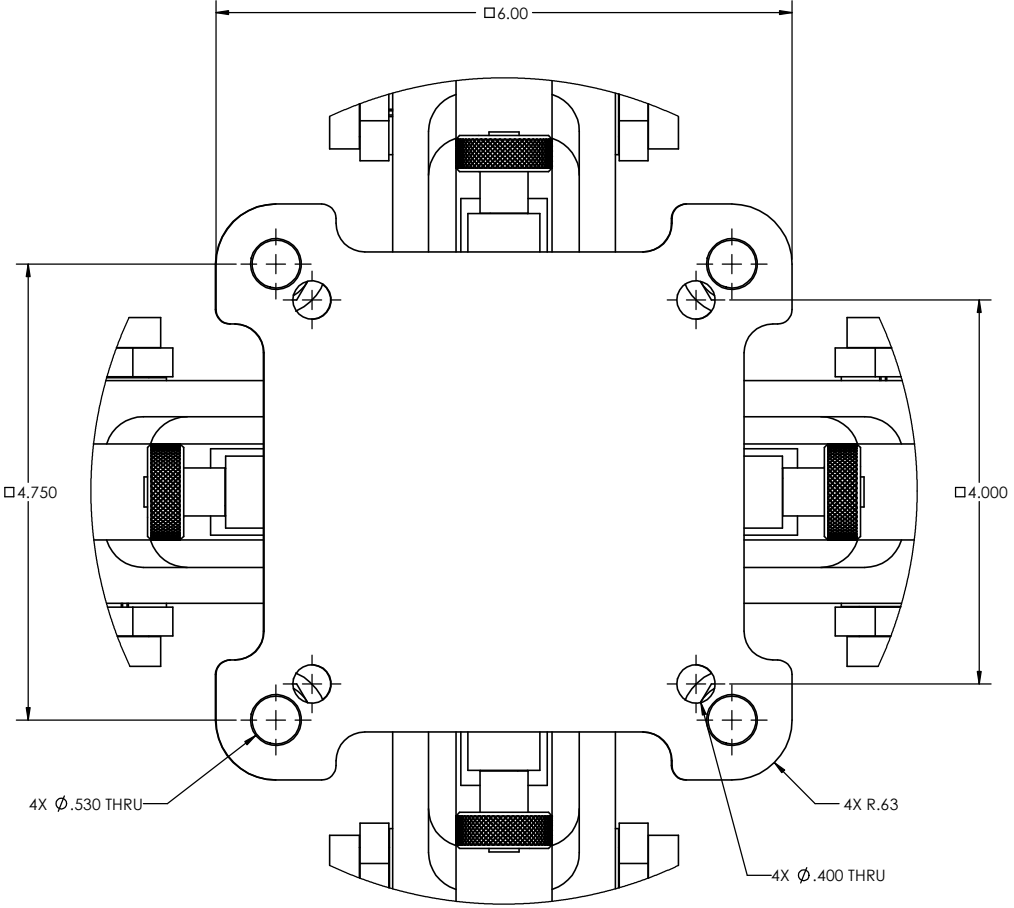
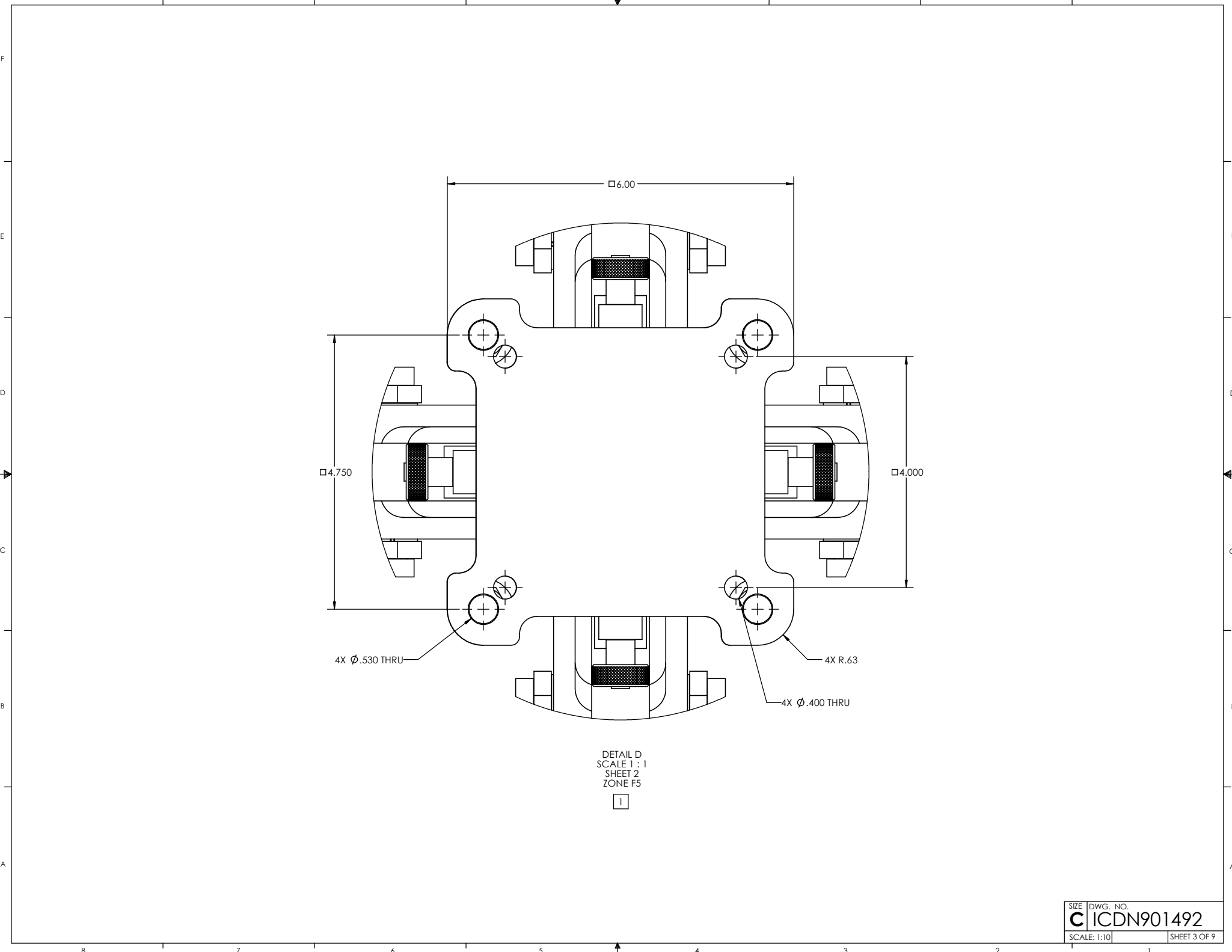

DETAIL D
SCALE 1 : 1
SHEET 2
ZONE F5
1

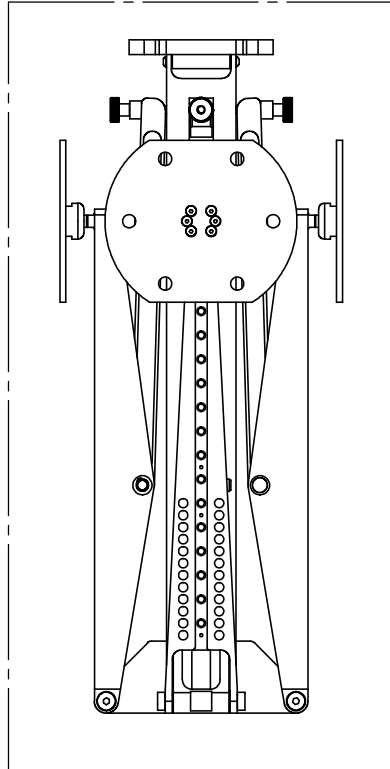

BOX 1 - 32" X 16" X 16"
 P/N - ACC-N901369-1
 HEAVY DUTY QUADPOD

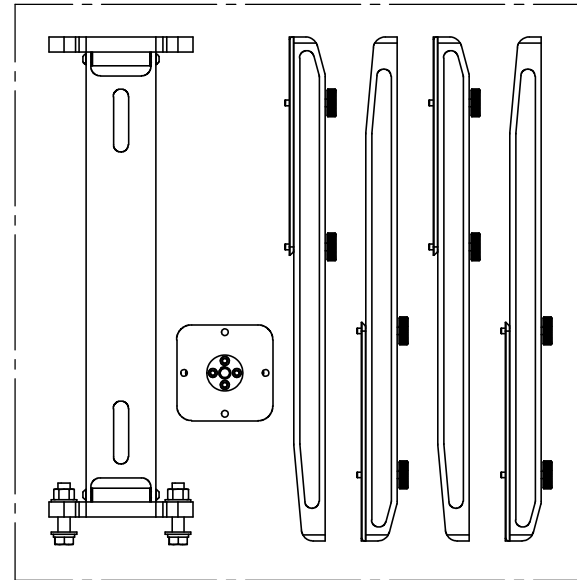

BOX 2 - 24" X 24" X 8"
 P/N - ACC-N901503-1
 SUPPLEMENTAL KIT, EXTENDED
 HEAVY DUTY QUADPOD

EXTENDED HEAVY DUTY QUADPOD SHIPPED IN TWO BOXES.
 SOME ASSEMBLY REQUIRED, SEE SHEET 5 THRU 9

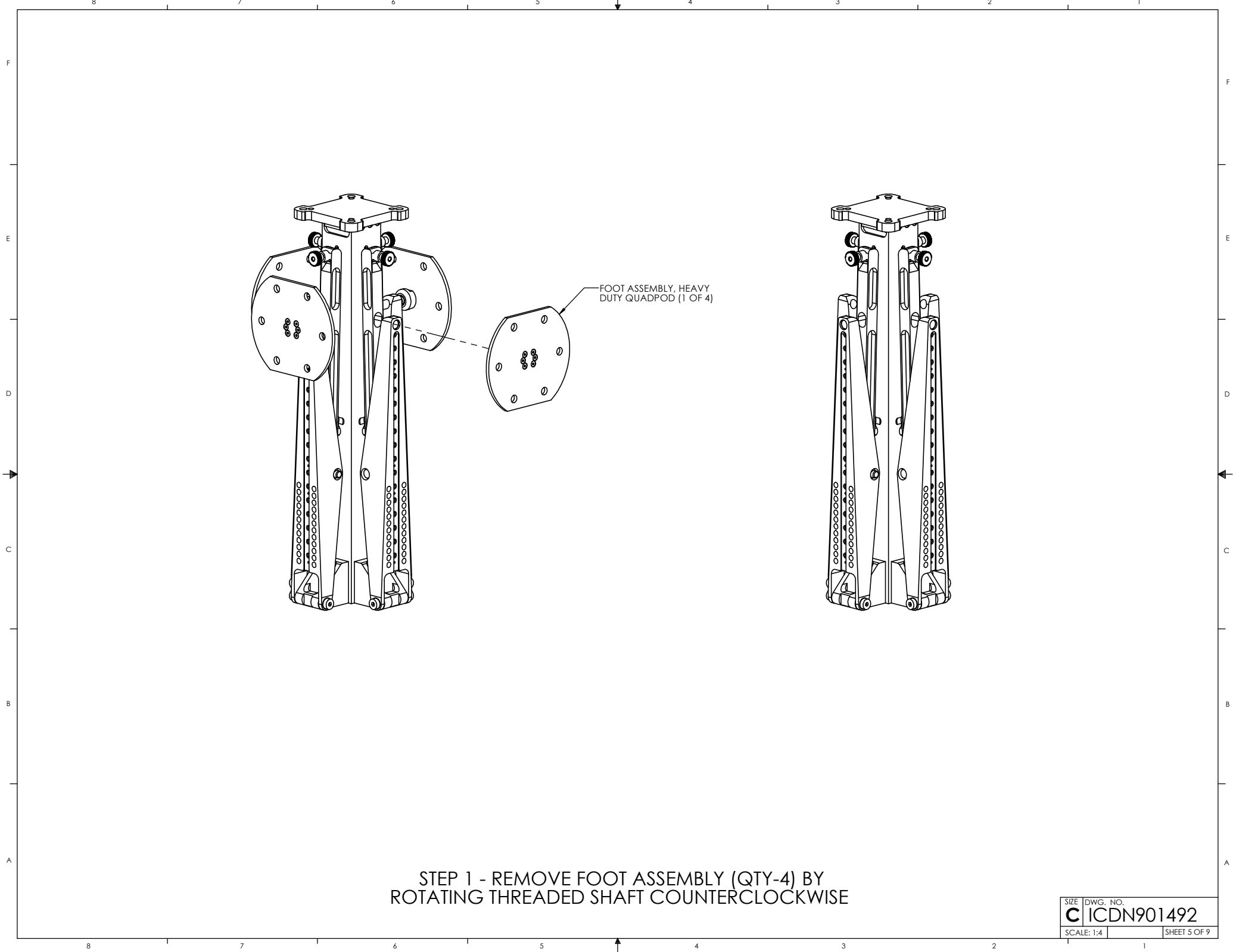

STEP 1 - REMOVE FOOT ASSEMBLY (QTY-4) BY
ROTATING THREADED SHAFT COUNTERCLOCKWISE

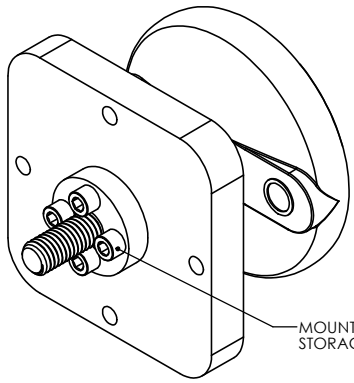

MAST LEVELING ASSEMBLY
(PACKAGED CONFIGURATION)

MOUNTING SCREWS
STORAGE LOCATION

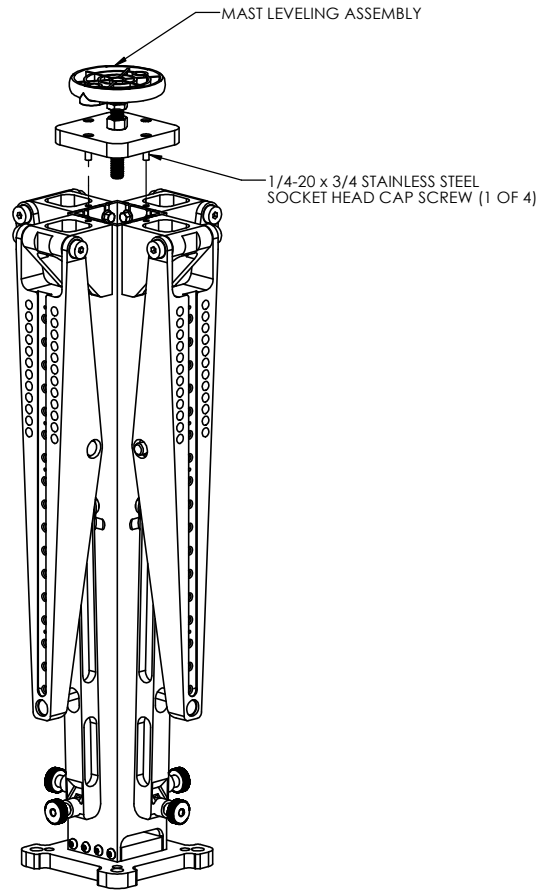

MAST LEVELING ASSEMBLY

1/4-20 x 3/4 STAINLESS STEEL
SOCKET HEAD CAP SCREW (1 OF 4)

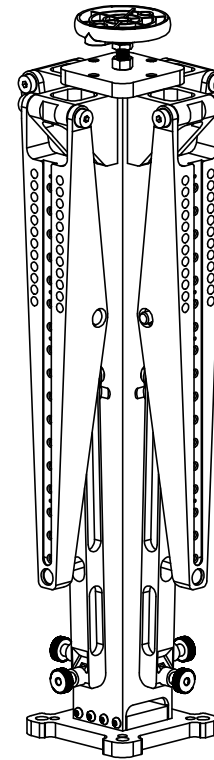

STEP 2 - ASSEMBLE MAST LEVELING ASSEMBLY USING THE SUPPLIED (4) 1/4-20 x 3/4 IN LONG STAINLESS STEEL SOCKET HEAD CAP SCREWS. TORQUE SCREWS TO 70 IN-LBS

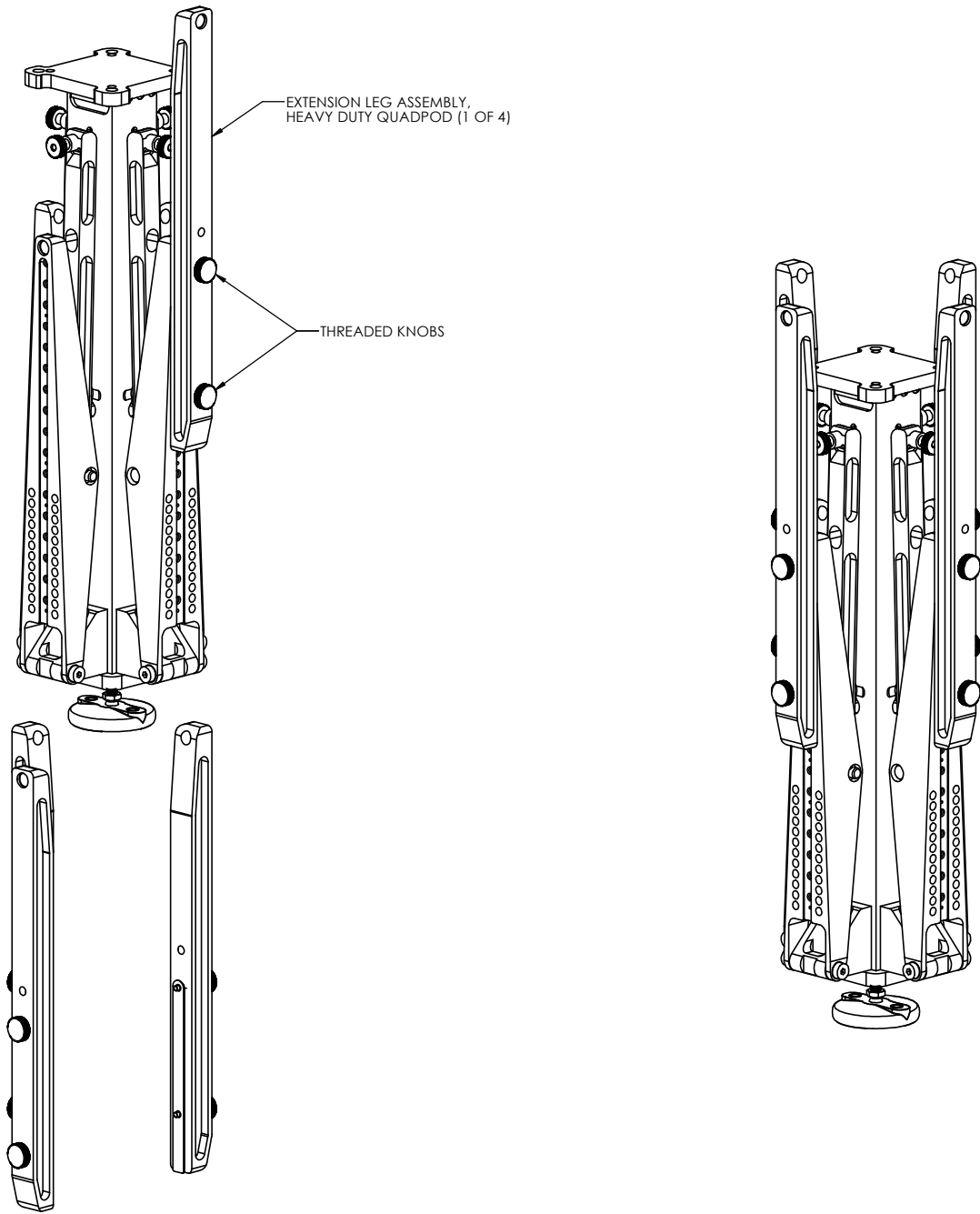

STEP 3 - LOOSEN INDICATED THREADED KNOBS THEN SLIDE
 EXTENSION LEG ASSEMBLY INTO DOVETAIL GROOVE. TIGHTEN
 THREADED KNOBS AT DESIRED EXTENSION LEG ASSEMBLY POSITION

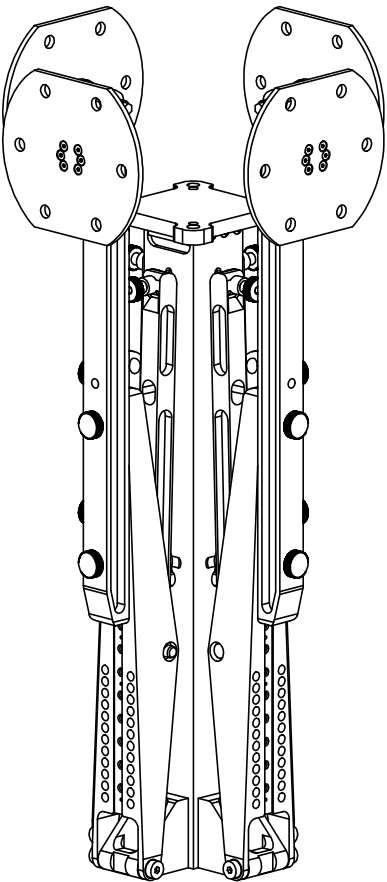
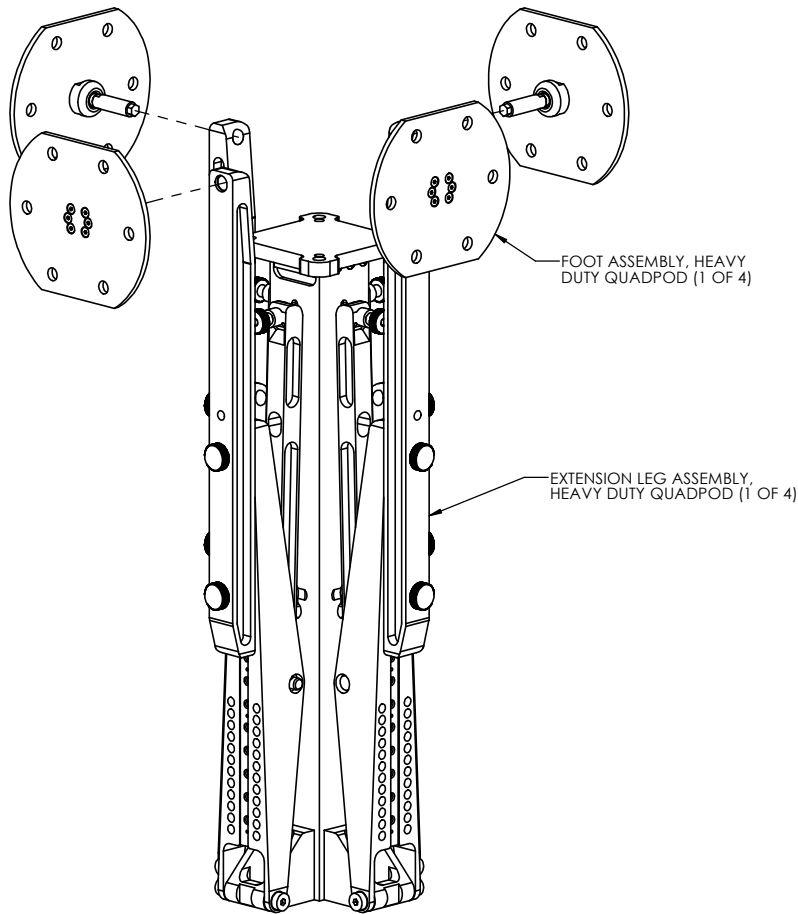

STEP 4 - INSTALL FOOT ASSEMBY (QTY-4) BY ROTATING THREADED SHAFT
CLOCKWISE INTO THREADED HOLE IN EXTENSION LEG ASSEMBLY

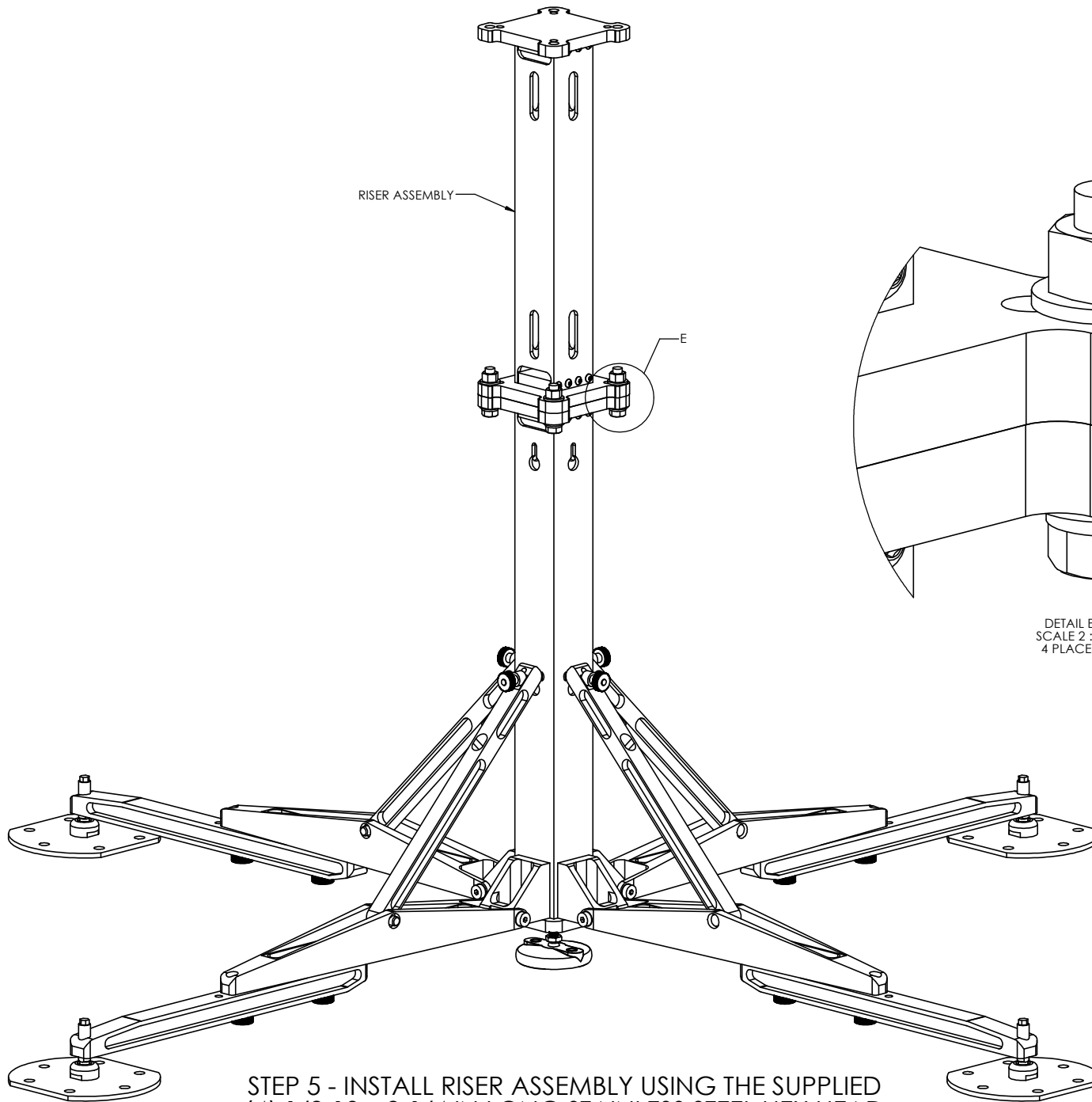

RISER ASSEMBLY

E

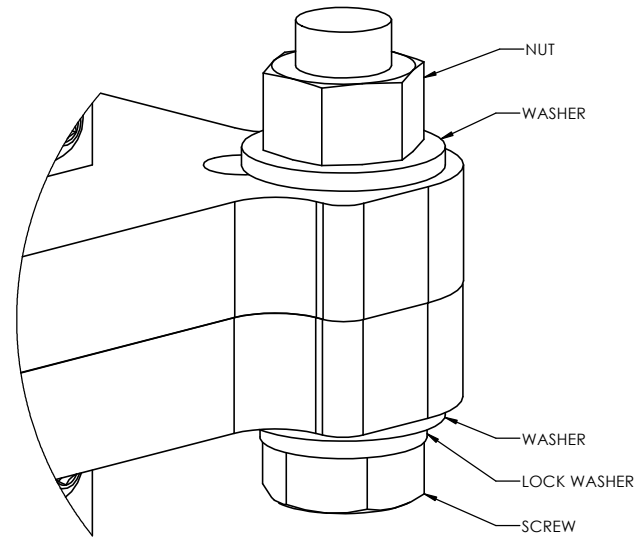

NUT

WASHER

WASHER

LOCK WASHER

SCREW

DETAIL E
SCALE 2 : 1
4 PLACES

STEP 5 - INSTALL RISER ASSEMBLY USING THE SUPPLIED (4) 1/2-13 x 2-1/4 IN LONG STAINLESS STEEL HEX HEAD CAP SCREWS AND CORRESPONDING WASHERS, LOCK WASHERS AND NUTS. TORQUE SCRES TO 45 FT-LBS