

# GPS Heading Unit (GHU)

Standard Series QLA Accessory for Improved Heading Accuracy

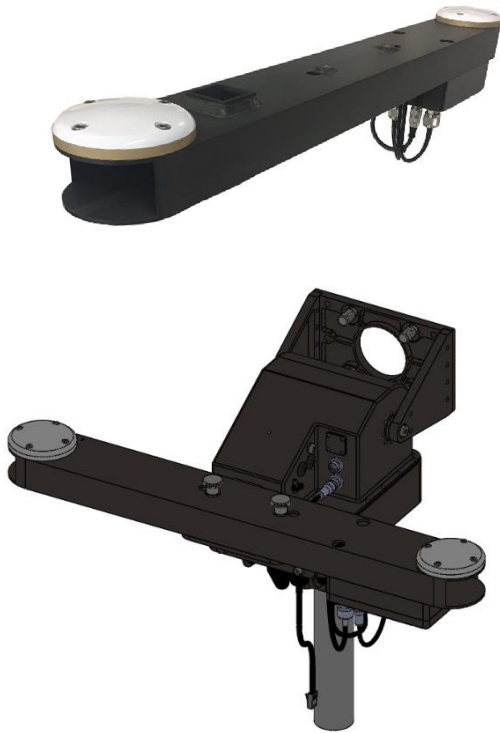

GHU shown installed on QLA-FER Series.

The QPAR GPS Heading Unit (GHU) is a tool-less bolt on accessory which uses GPS technology to provide accurate heading when paired with a QLA antenna positioner.

The standard model GHU was developed to work with the QLA -EER, -FER, and -RPT Series of antenna positioner systems. Higher frequency line of sight radio and satellite links have antenna beam widths of less than a few degrees which can make the initial alignment process extremely difficult.

This tool provides QLA antenna positioners with a more accurate heading to place narrow beam line of sight and satellite antenna links on target. After the initial point using the GHU, the QLA antenna positioner will use its built-in closed loop RF peaking tools to optimize and maintain the link.

This GHU works with the EER, FER, and RPT Series of antenna positioners. QPAR Antennas also offers a GHU to work with the EBP series. If desired the GHU can be adapted to other QLA series antenna positioners.

The GHU is the perfect solution for auto acquisition of high frequency narrow beam antennas.

## TECHNICAL SPECIFICATIONS - GPS Heading Unit

Power	Powered by QLA Antenna Positioner (Single Power/Data cable included)
Material / Finish	Aluminum w/ stainless steel hardware / Hard coat anodize
GPS Receiver Type	GNSS, L1, RTK
GPS Signals Received	GPS, GLONASS
Data I/O Protocol	NMEA 0183
Heading Accuracy	Less than 1 deg *
Operating/Storage Temp	-40 to 158°F (-40 to 70°C)
Dimensions	Height:7.53" (19.1 cm), Width: 27.5" (69.9 cm), Depth: 3.5" (7.6 cm)
Weight	6 lbs (2.7 kg)
Mounting Interface	Captive Knobs and alignment pins, Tool-less installation to QLA antenna positioners
Mounting Options	Config shown for QLA -EER, -FER, AND -RPT series

REV A

Specifications subject to change without notice

\* Depends on multipath environment and number of satellites in view