

REV	DESCRIPTION	DATE	APPROVED
B	IR800531	2019-02-06	CLC

NOTES: UNLESS OTHERWISE SPECIFIED

1. QPAR LINKALIGN-360MPT-40 CONFIGURABLE OPTIONS PER TABLE I, SHOWN WITHOUT COUNTERWEIGHTS. QPAR LINKALIGN-360MPT-40 SUPPLIED WITH 60 LBS OF COUNTERWEIGHTS (EQUIVALENT TO 60 FT-LBS OF TORQUE)
2. USE INTERFACE CONTROL DRAWING IN CONJUNCTION WITH DATASHEET N500159
3. SEE TABLE II FOR AVAILABLE QPAR LINKALIGN-360MPT-40 ACCESSORY OPTIONS
4. 48VDC POWER SUPPLY INCLUDED WITH POSITIONER. NOT SHOWN IN DRAWING
5. HARD COAT ANODIZE ALUMINUM CONSTRUCTION WITH STAINLESS STEEL HARDWARE
6. 400° (+/-200°) AZIMUTH TRAVEL WITH 12°/SEC DRIVE RATE (NO LOAD)
7. 180° (+/-90°) ELEVATION TRAVEL WITH 7°/SEC DRIVE RATE (NO LOAD)
8. -22° TO 140°F (-30° TO 60°C) OPERATIONAL TEMPERATURE RANGE, -40 TO 158°F (-40 TO 70°C) NON-OPERATIONAL TEMPERATURE RANGE
9. 0.1° FEEDBACK RESOLUTION IN ALL AXES
10. AZIMUTH AND ELEVATION BACKLASH LESS THAN 0.1°
11. 21.38" (54.3 cm) HIGH X 11.50" (29.2 cm) WIDE X 16.00" (40.6 cm) DEEP. DIMENSIONS APPLY WHEN POSITIONER IS AT 0° AZIMUTH AND 0° ELEVATION ANGLES
12. WEIGHT APPROXIMATELY 99 LBS (44.9 kg)
13. PAYLOAD SHALL NOT EXCEED 200 LB (90.7 kg) (INCLUDING COUNTERWEIGHTS) OR 40 FT-LBS OF TORQUE ABOUT THE ELEVATION AXIS. EFFORT SHOULD BE MADE TO BALANCE ELEVATION PAYLOAD AS MUCH AS POSSIBLE BY USING THE (6) 10 LB COUNTERWEIGHTS PROVIDED. TO CALCULATE TORQUE, TAKE THE DISTANCE FROM THE PAYLOAD CENTER OF GRAVITY TO DATUM, -B- IN FEET AND MULTIPLY BY THE PAYLOAD WEIGHT. POSITIONER IS BACKDRIVABLE WHEN NOT POWERED UP OR IN STANDBY MODE. ELEVATION HOLDING TORQUE IN THIS STATE IS 20 FT-LBS
14. TABLE TOP MOUNTING HOLES
15. CENTER OF GRAVITY 0.2" (0.5 cm) IN THE X-DIRECTION, 9.2" (23.4 cm) IN THE Y-DIRECTION AND 0.2" (0.5 cm) IN THE Z-DIRECTION

NOTES CONTINUED ON SHEET 6

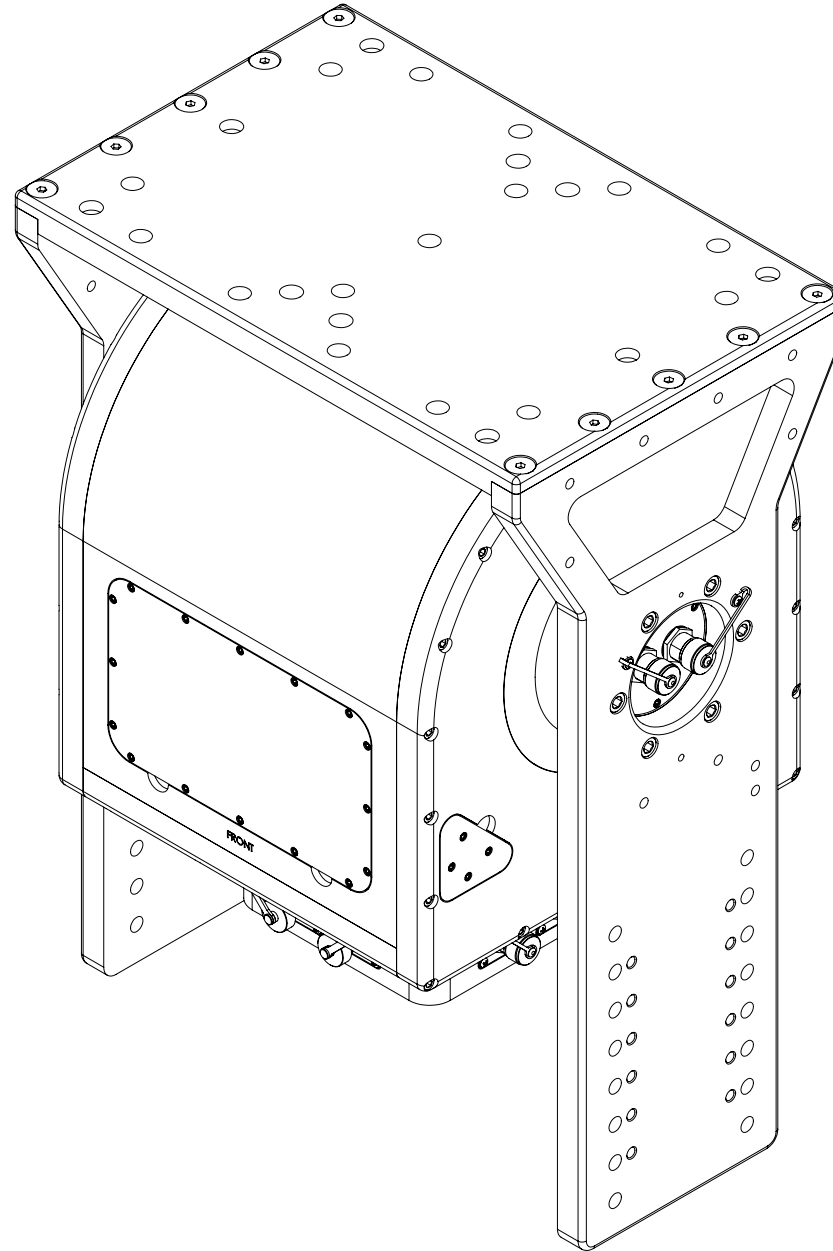
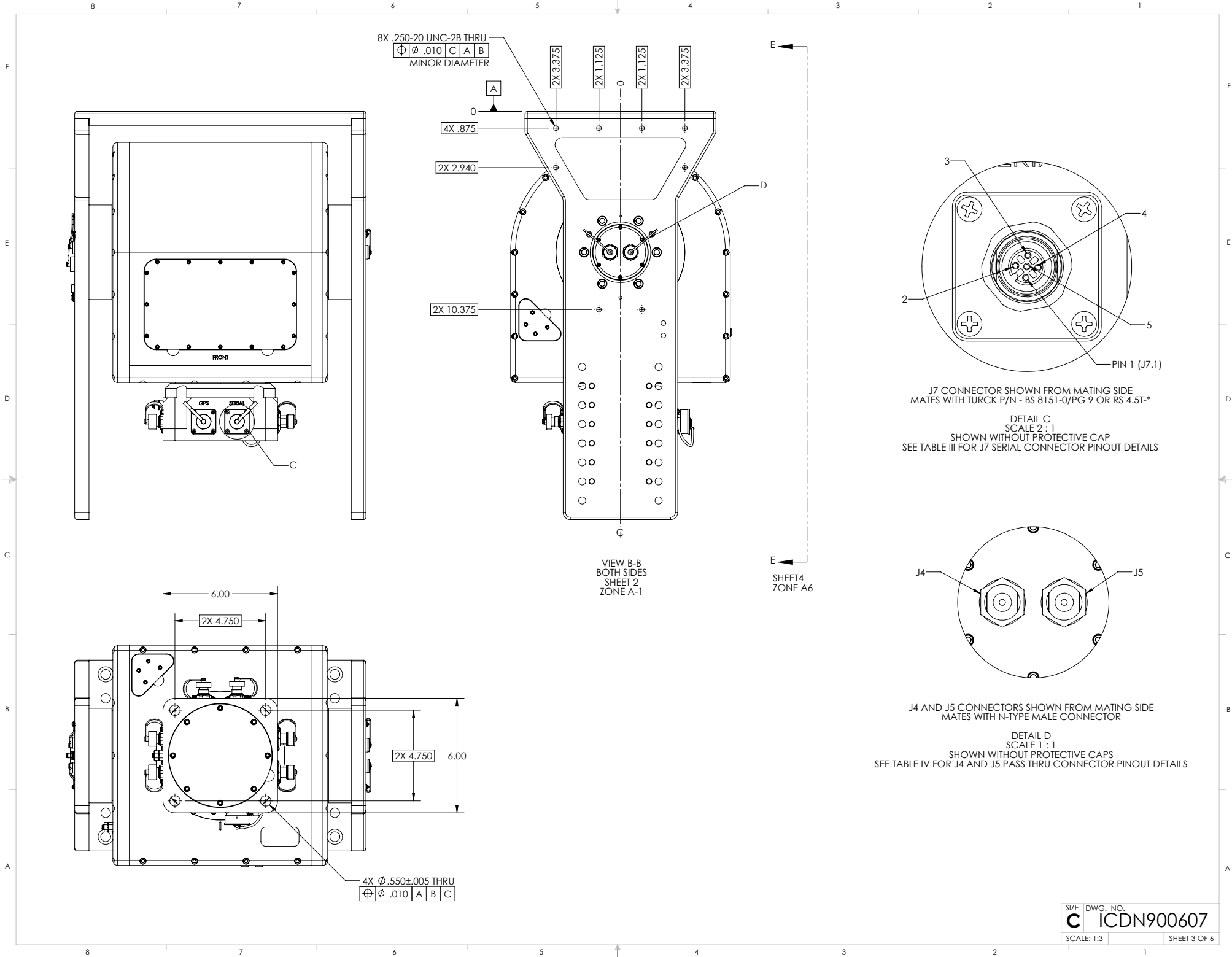

TABLE I	
BUILDING A PART NUMBER	STANDARD OPTIONS
LA-360MPT - 40 - 100	<<EXAMPLE
SHIELDED ETHERNET CABLE STANDARD LENGTHS	
050 =	50 ft
100 =	100 ft
150 =	150 ft
200 =	200 ft
250 =	250 ft
300 =	300 ft
XXX =	Custom length in feet
XXXX =	Add "C" to end of cable length for unterminated mating connector
CUSTOM CONFIGURATION	
= Standard options - leave blank	
MOTOR DRIVES AND PAYLOAD	
40 =	Az 25 ft-lbs @ 12°/s, El 40 ft-lbs @ 7°/s, 200 lb payload. Typically paired with 3-6 ft antenna (+/-200° azimuth, +/-90° elevation)
MODEL	
LA-360MPT = LinkAlign-360MPT (See motor drives and payload section for positioner travel range info)	

TABLE II (MPT-40 ACCESSORY OPTIONS)		
ACCESSORY DESCRIPTION	ACCESSORY PART NUMBER	ACCESSORY ICD
RISER ASSEMBLY, MPT-40	ACC-N900553-XX	ICDN900553
CROSS ELEVATION DRIVE ASSEMBLY KIT, MPT-40	ACC-N900555-1	ICDN900555
QUADPOD, MPT-40	ACC-N900577-1	ICDN900577
TRANSIT CASE, MPT-40	TC-LA-360MPT-40-1	N/A

SYMBOL KEY		UNLESS OTHERWISE SPECIFIED:			DRAWN		C. CHEYNE		2019-02-06		QPAR ANTENNAS USA, LLC	
□	NOTE	○	PL ITEMS	DIMENSIONS ARE IN INCHES			CHECKED	S. CHEYNE	2019-02-06		TITLE:	
PROPRIETARY AND CONFIDENTIAL THE INFORMATION CONTAINED IN THIS DRAWING IS THE SOLE PROPERTY OF QPAR USA. ANY REPRODUCTION IN PART OR AS A WHOLE WITHOUT THE WRITTEN PERMISSION OF QPAR ANTENNAS USA IS PROHIBITED.				TOLERANCES			ME APPR.	S. CHEYNE	2019-02-06			QPAR LINKALIGN-360MPT-40 INTERFACE CONTROL DRAWING
				ANGLE ± .5 DEGREES TWO PLACE DECIMAL ± .030 THREE PLACE DECIMAL ± .010			IE APPR.					
				INTERPRET DIM AND TOL PER ASME Y14.5M - 1994								
				THIRD ANGLE PROJECTION DO NOT SCALE DRAWING			PART NO.		SEE TABLE I		SIZE	REV
				QPAR ANTENNAS USA, LLC San Diego, CA 92020 www.qparusa.com							ICDN900607 SCALE: 1:2	B SHEET 1 OF 6



8X .250-20 UNC-2B THRU
 $\oplus \phi .010$ C | A | B
 MINOR DIAMETER

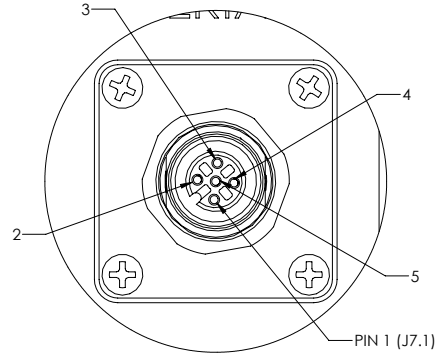
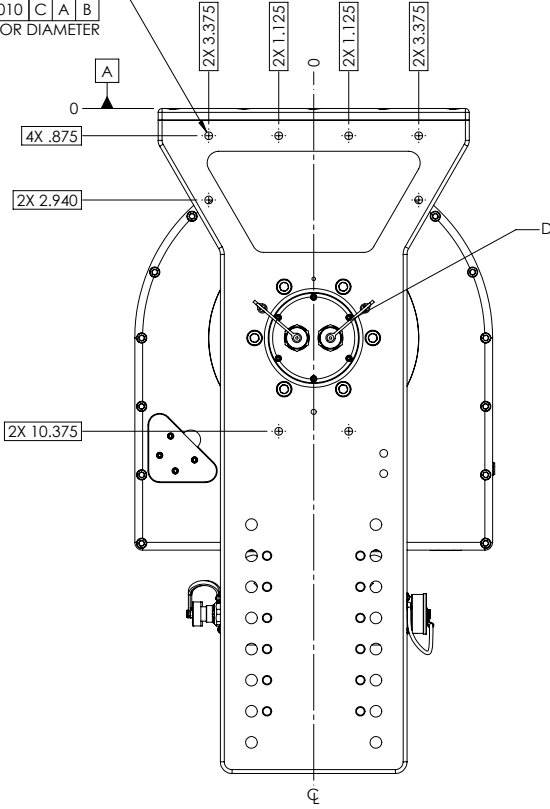

J7 CONNECTOR SHOWN FROM MATING SIDE
 MATES WITH TURCK P/N - BS 8151-0/PG 9 OR RS 4.5T-*

DETAIL C
 SCALE 2 : 1
 SHOWN WITHOUT PROTECTIVE CAP
 SEE TABLE III FOR J7 SERIAL CONNECTOR PINOUT DETAILS

VIEW B-B
 BOTH SIDES
 SHEET 2
 ZONE A-1

SHEET 4
 ZONE A6

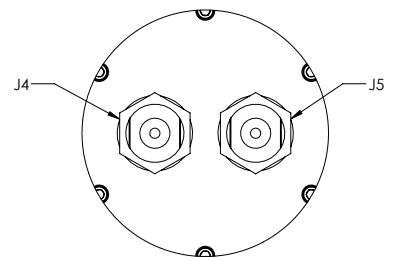
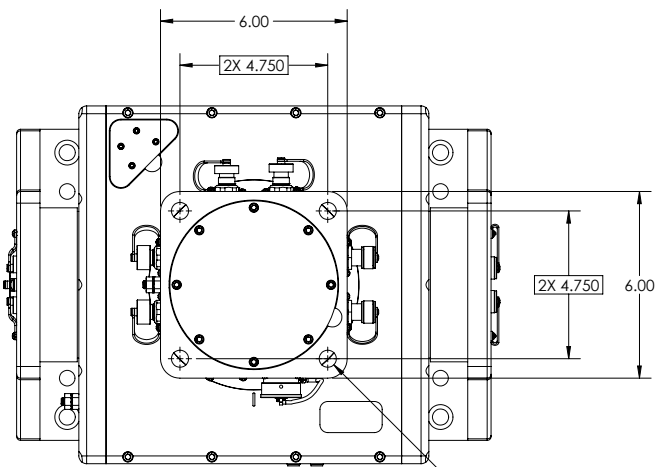

J4 AND J5 CONNECTORS SHOWN FROM MATING SIDE
 MATES WITH N-TYPE MALE CONNECTOR

DETAIL D
 SCALE 1 : 1
 SHOWN WITHOUT PROTECTIVE CAPS
 SEE TABLE IV FOR J4 AND J5 PASS THRU CONNECTOR PINOUT DETAILS

4X $\phi .550 \pm .005$ THRU
 $\oplus \phi .010$ A | B | C

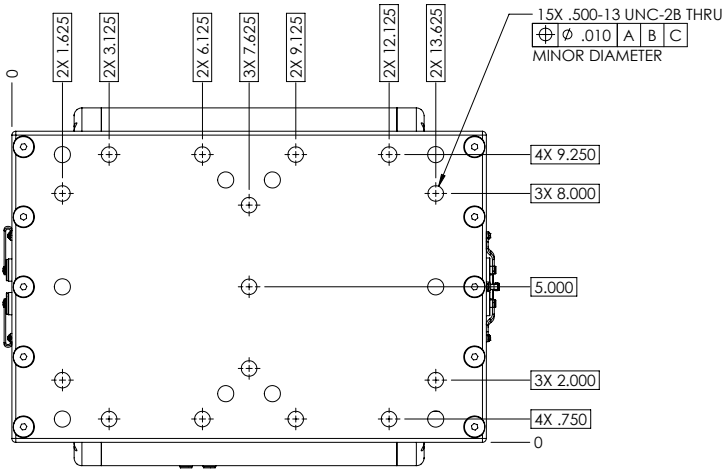
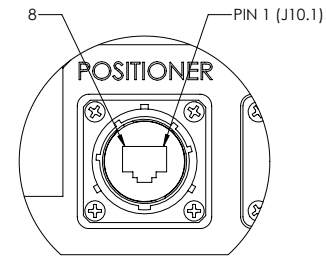

TABLE TOP MOUNTING HOLES

14



J10 CONNECTOR SHOWN FROM MATING SIDE
 MATES WITH AMPHENOL P/N RJF68

DETAIL F
 SCALE 1 : 1
 SHOWN WITHOUT PROTECTIVE CAP
 SEE TABLE III FOR J10 CONNECTOR PINOUT DETAILS

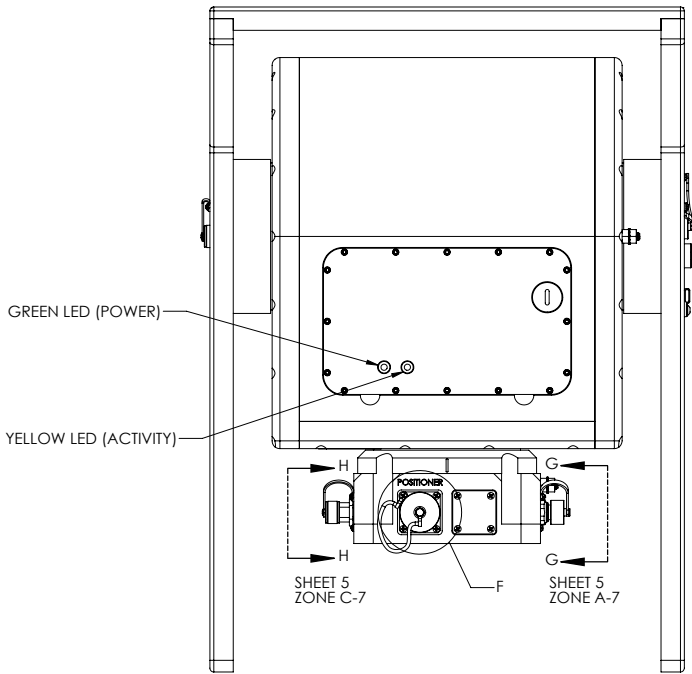

VIEW E-E
 SHEET 3
 ZONE C-3

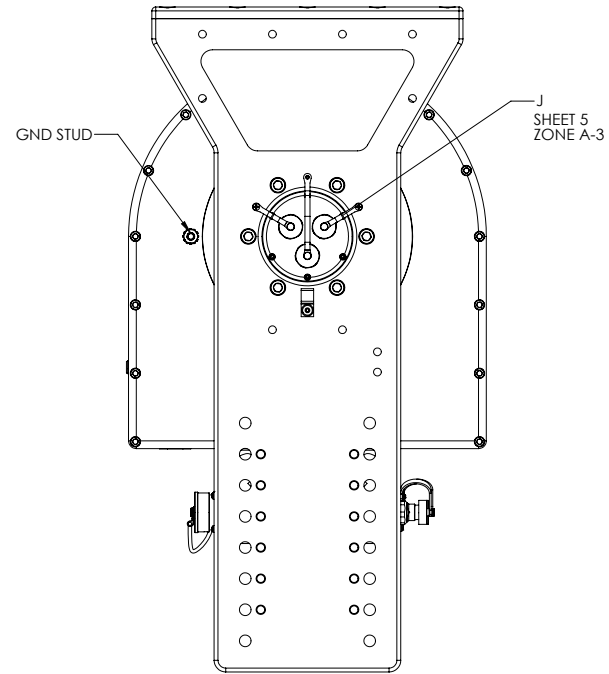

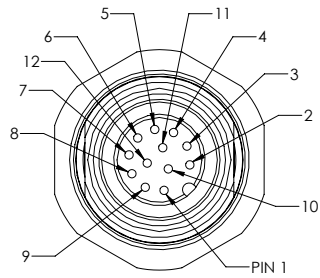

DETAIL K
SCALE 3 : 1

P1 & P2 CONNECTOR PINOUT DETAILS
2 PLACES

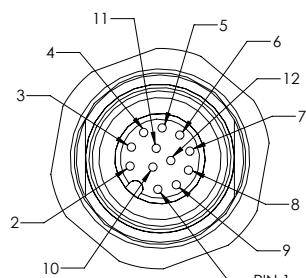

DETAIL L
SCALE 3 : 1

J1 & J2 CONNECTOR PINOUT DETAILS
2 PLACES

TABLE III (CONNECTOR FUNCTION)	
CONNECTOR DESIGNATION	FUNCTION
J7.1	DC RETURN FOR QPARUSA JOYSTICK
J7.2	NOT USED
J7.3	(B) TxD+/RxD+ DATA LINE
J7.4	(A) TxD-/RxD- DATA LINE
J7.5	DC POWER FOR QPARUSA JOYSTICK
J10.1	DATA PAIR 1
J10.2	DATA PAIR 1
J10.3	DATA PAIR 2
J10.4	+48-56VDC PoE POWER INPUT
J10.5	+48-56VDC PoE POWER INPUT
J10.6	DATA PAIR 2
J10.7	DC RETURN FOR PoE INPUT
J10.8	DC RETURN FOR PoE INPUT

TABLE IV (WIRING DIAGRAM)	
FROM	TO
P1.1	J1.1
↓	↓
P1.12	J1.12
P2.1	J2.1
↓	↓
P2.12	J2.12
J8.1	J4.1
J9.1	J5.1

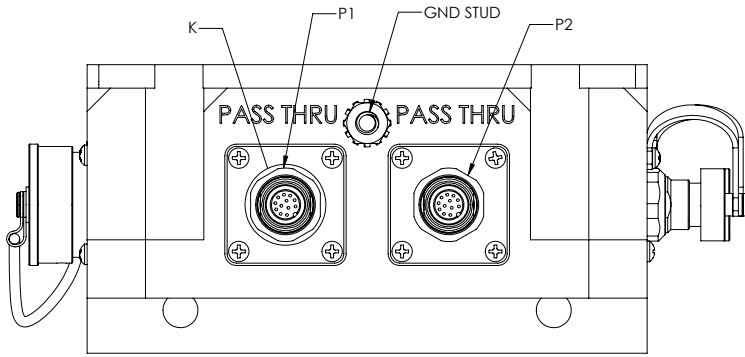

P1 & P2 CONNECTORS SHOWN FROM MATING SIDE
MATES WITH TURCK P/N B 81121-0/PG9 OR RK 12T-*

SECTION G-G
SCALE 1 : 1
SHEET 4
ZONE A-7

SHOWN WITHOUT PROTECTIVE CAPS
SEE TABLE IV FOR P1 & P2 PASS THRU CONNECTOR PINOUT DETAILS

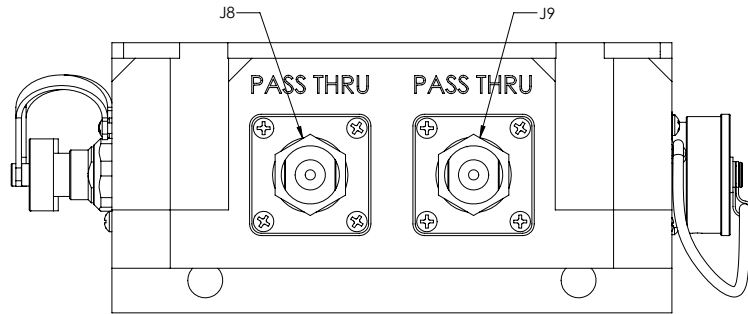

J8 & J9 CONNECTORS SHOWN FROM MATING SIDE
MATES WITH N-TYPE MALE CONNECTOR

SECTION H-H
SCALE 1 : 1
SHEET 4
ZONE A-8

SHOWN WITHOUT PROTECTIVE CAP
SEE TABLE IV FOR J8 & J9 PASS THRU CONNECTOR PINOUT DETAILS

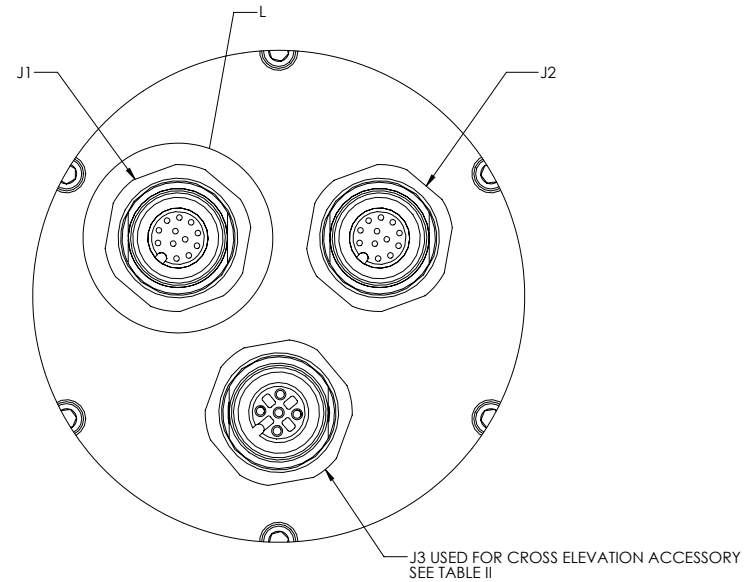

J1 & J2 CONNECTORS SHOWN FROM MATING SIDE
MATES WITH TURCK P/N BS 81121-0/PG9 OR RS 12T-*

DETAIL J
SCALE 2 : 1
SHEET 4
ZONE C-2

SHOWN WITHOUT PROTECTIVE CAPS
SEE TABLE IV FOR J1 & J2 PASS THRU CONNECTOR PINOUT DETAILS

NOTES CONTINUED:

- 16 COUNTERWEIGHTS SHOWN AT MAXIMUM ADDITIONAL ELEVATION TORQUE OF 60 FT-LBS TO ADJUST ELEVATION TORQUE COUNTERWEIGHT LOCATIONS MAY BE ADJUSTED USING MOUNTING HOLES ON ELEVATION ARM. SEE DIMENSIONS ON VIEW A-A TO CALCULATE TORQUE VALUES AT RESPECTIVE MOUNTING HOLE LOCATIONS
- 17 COUNTERWEIGHTS MUST ALTERNATE FROM N900557-1 TO N900557-2 OR VICE VERSA WHEN COUNTERWEIGHTS ARE STACKED TOGETHER

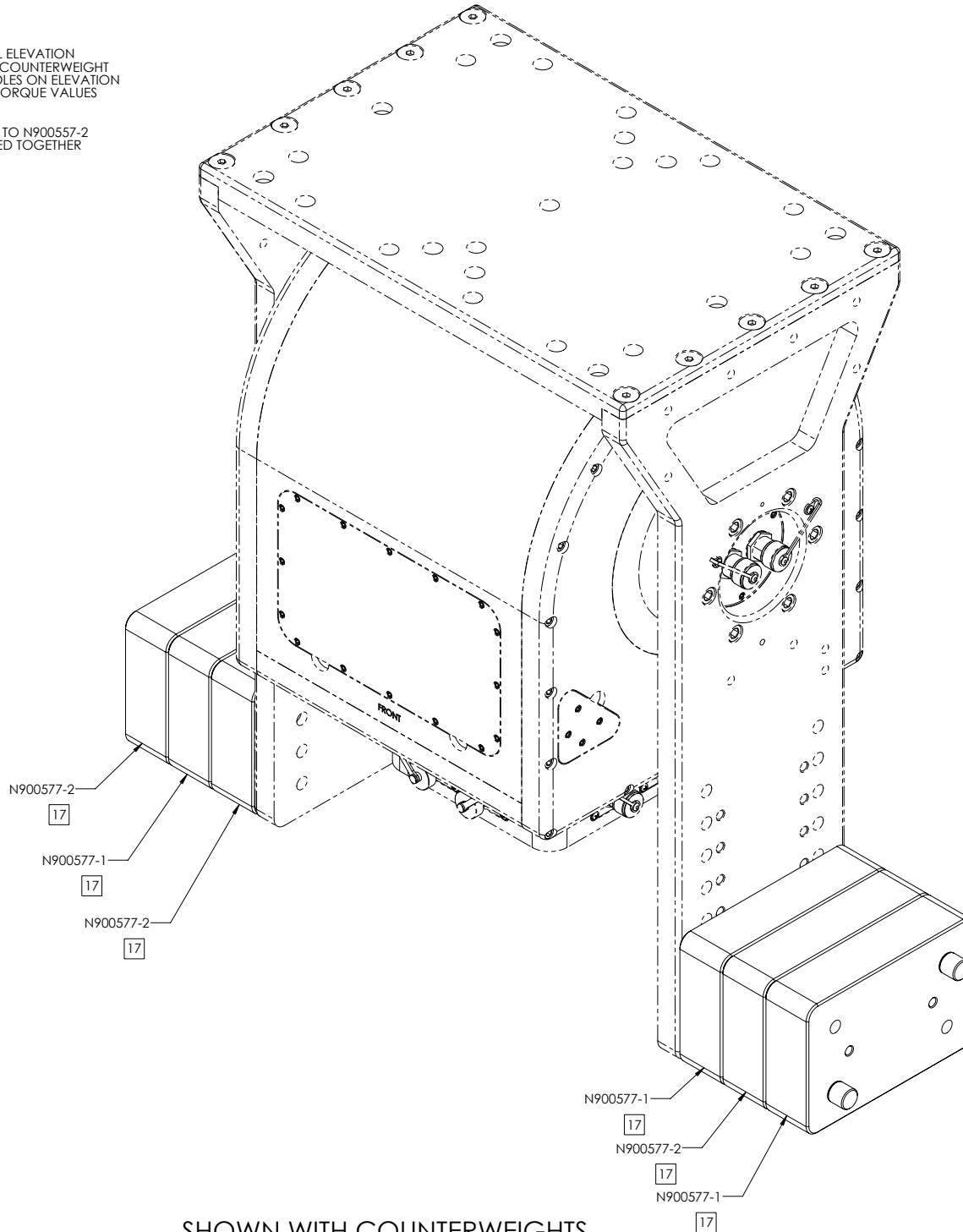

SHOWN WITH COUNTERWEIGHTS