

REV	DESCRIPTION	DATE	APPROVED
B	CN600564	2018-08-06	CLC

NOTES: UNLESS OTHERWISE SPECIFIED

- QPAR LINKALIGN-360MPT-10 CONFIGURABLE OPTIONS PER TABLE I
- USE INTERFACE CONTROL DRAWING IN CONJUNCTION WITH DATASHEET AS DENOTED IN TABLE II
- 48 - 56VDC POWER SUPPLY INCLUDED WITH POSITIONER. NOT SHOWN IN DRAWING
- HARD COAT ANODIZE ALUMINUM CONSTRUCTION WITH STAINLESS STEEL HARDWARE
- 200° (+/-100°) AZIMUTH TRAVEL WITH 2.6°/SEC DRIVE RATE (NO LOAD)
- 180° (+/-90°) ELEVATION TRAVEL WITH 2.6°/SEC DRIVE RATE (NO LOAD)
- 22° TO 140°F (-30° TO 60°C) OPERATIONAL TEMPERATURE RANGE. -40 TO 158°F (-40 TO 70°C) NON-OPERATIONAL TEMPERATURE RANGE
- 0.1° FEEDBACK RESOLUTION IN ALL AXES
- AZIMUTH AND ELEVATION BACKLASH LESS THAN 1°
- 8.86" (22.5 cm) HIGH X 9.48" (24.1 cm) WIDE X 6.00" (15.2 cm) DEEP. DIMENSIONS APPLY WHEN POSITIONER IS AT 0° AZIMUTH AND 0° ELEVATION ANGLES
- WEIGHT APPROXIMATELY 14.0 LBS (6.4 kg) NOT INCLUDING PoE CABLE
- PAYLOAD SHALL NOT EXCEED 15 LBS OR 8 FT-LBS OF TORQUE ABOUT THE ELEVATION AXIS. TO CALCULATE TORQUE, TAKE THE DISTANCE FROM THE PAYLOAD CENTER OF GRAVITY TO DATUM -C- IN FEET AND MULTIPLY BY THE PAYLOAD WEIGHT
- RADIO OR AUXILIARY MOUNTING HOLES (BOTH SIDES)
- CENTER OF GRAVITY 0.5" (1.3 cm) IN THE X-DIRECTION, 0" (0 cm) IN THE Y-DIRECTION AND 4.2" (10.7 cm) IN THE Z-DIRECTION

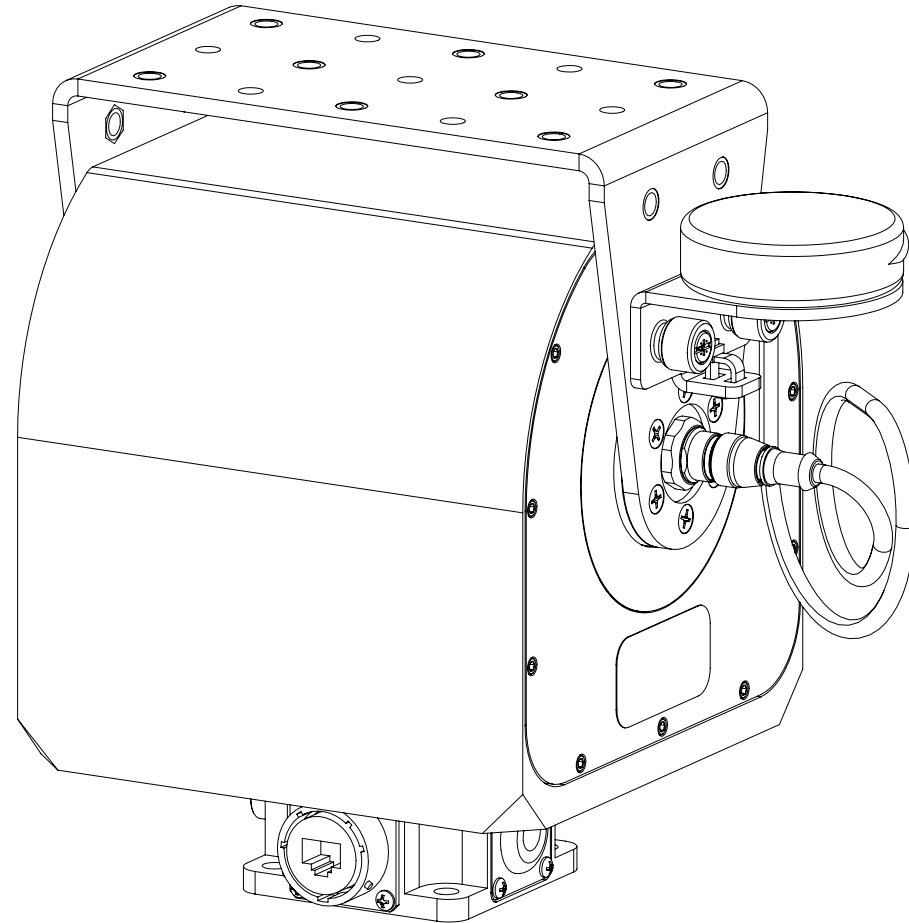
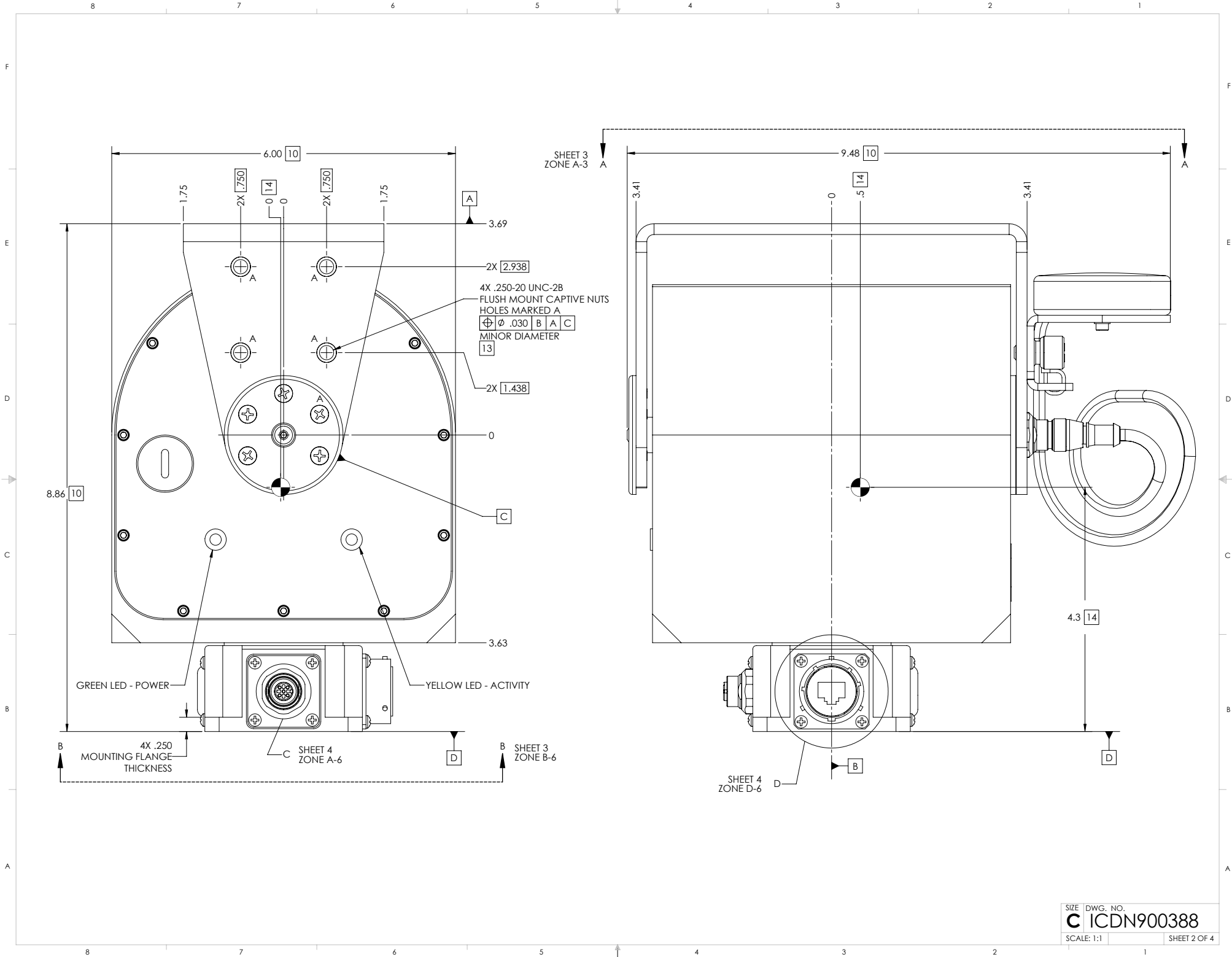
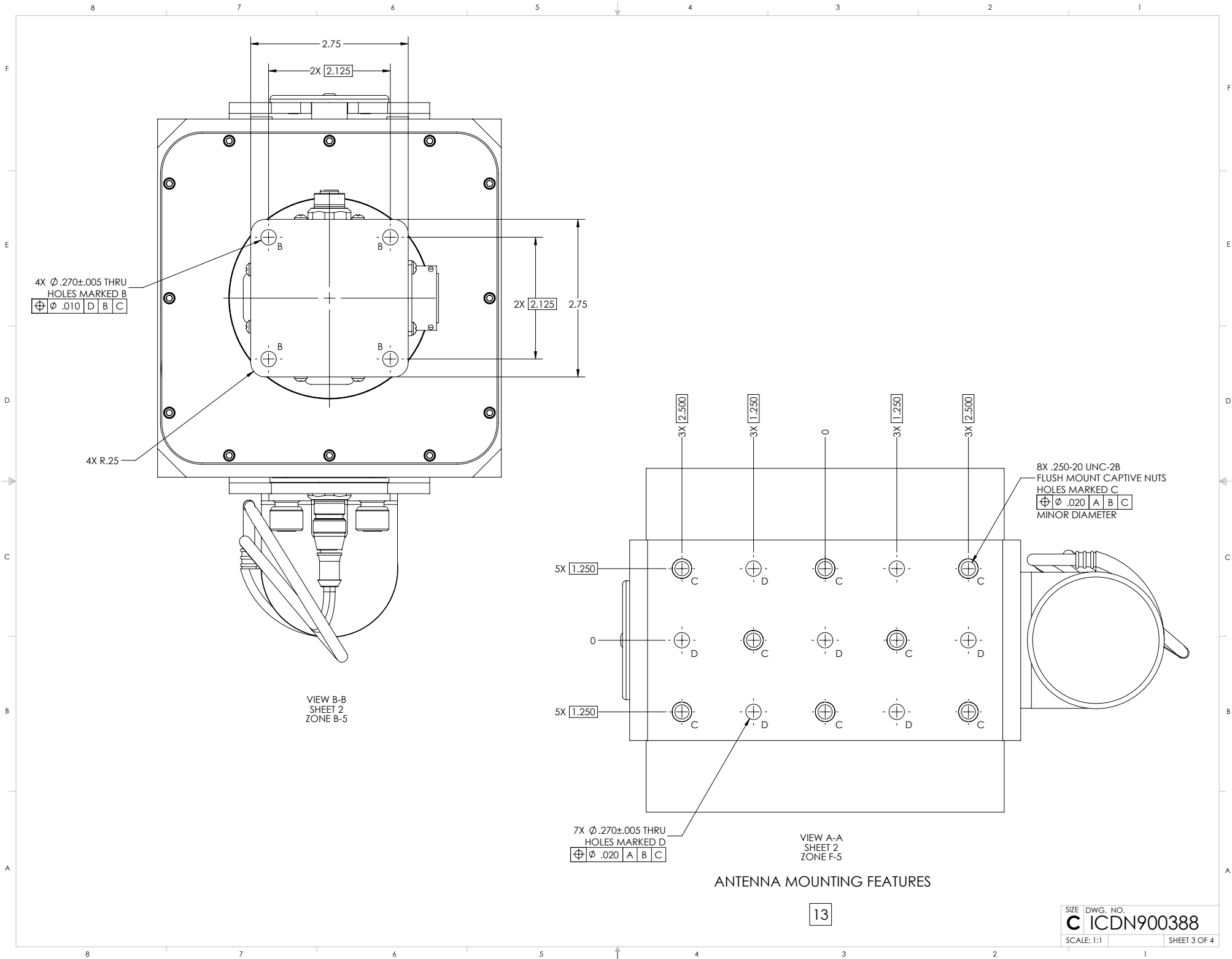

TABLE I	
BUILDING A PART NUMBER	STANDARD OPTIONS
LA-360MPT - 10 - - - 100	<<EXAMPLE
	SHIELDED ETHERNET CABLE STANDARD LENGTHS
	050 = 50 ft
	100 = 100 ft
	150 = 150 ft
	200 = 200 ft
	250 = 250 ft
	300 = 300 ft
	XXX = Custom length in feet
	XXXC = Add "C" to end of cable length for unterminated mating connector
	CUSTOM CONFIGURATION
	= Standard options - leave blank
	MOTOR DRIVES AND PAYLOAD
	10 = Az 8 ft-lbs @ 2.6°/s, El 8 ft-lbs @ 2.6°/s, 15 lb payload. Typically paired with ~1 ft antenna
	11 = Az 20 ft-lbs @ 6.5°/s, El 20 ft-lbs @ 6.5°/s, 15 lb payload. Typically paired with ~1 ft antenna
	MODEL
	LA-360MPT = LinkAlign-360MPT (+/-200° azimuth, +/-90° elevation)

TABLE II	
PART NUMBER	DATASHEET NUMBER
LA-360MPT-10	N500132
LA-360MPT-11	N500147

SYMBOL KEY <input type="checkbox"/> NOTE <input type="checkbox"/> PL ITEMS PROPRIETARY AND CONFIDENTIAL THE INFORMATION CONTAINED IN THIS DRAWING IS THE SOLE PROPERTY OF QPAR USA. ANY REPRODUCTION IN PART OR AS A WHOLE WITHOUT THE WRITTEN PERMISSION OF QPAR ANTENNAS USA IS PROHIBITED. QPAR ANTENNAS USA, LLC San Diego, CA 92020 www.qparusa.com	UNLESS OTHERWISE SPECIFIED: DIMENSIONS ARE IN INCHES TOLERANCES ANGLE ± .5 DEGREES TWO PLACE DECIMAL ±.030 THREE PLACE DECIMAL ±.010 INTERPRET DIM AND TOL PER ASME Y14.5M - 1994 THIRD ANGLE PROJECTION DO NOT SCALE DRAWING	DRAWN S. CHEYNE 2016-07-14 CHECKED C. CHEYNE 2018-08-06 ME APPR. S. CHEYNE 2016-07-14 EE APPR.	QPAR ANTENNAS USA, LLC TITLE: QPAR LINKALIGN-360MPT-10 INTERFACE CONTROL DRAWING SIZE ICG. NO. C DWN900388 SCALE: 1:1	REV B SHEET 1 OF 4
		SEE TABLE I	PART NO.	REV B
		QPAR ANTENNAS USA, LLC		
		SHEET 1 OF 4		





4X $\varnothing .270 \pm .005$ THRU
HOLES MARKED B
 $\varnothing .010$ D | B | C

4X R.25

VIEW B-B
SHEET 2
ZONE B-5

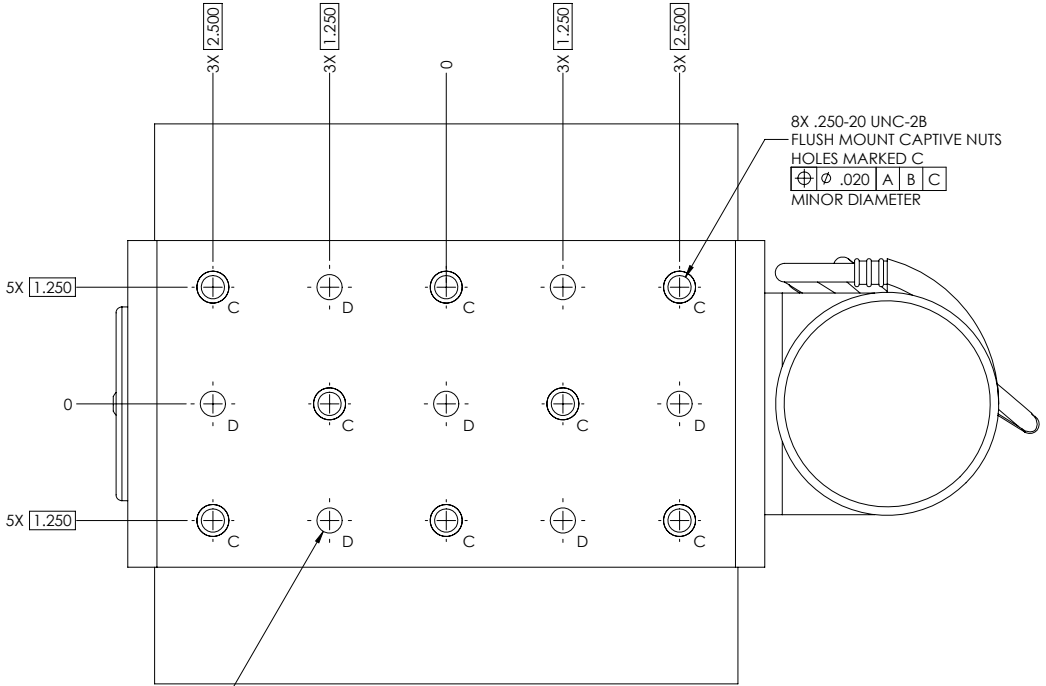

7X $\varnothing .270 \pm .005$ THRU
HOLES MARKED D
 $\varnothing .020$ A | B | C

VIEW A-A
SHEET 2
ZONE F-5

ANTENNA MOUNTING FEATURES

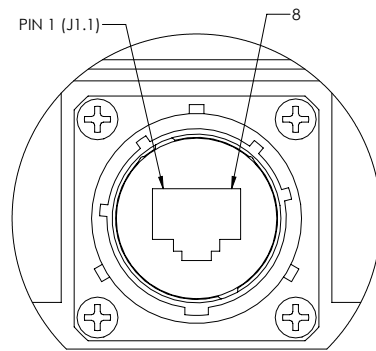

J1 CONNECTOR SHOWN FROM MATING SIDE
MATES WITH AMPHENOL P/N - RJF6B

DETAIL D
SCALE 2 : 1
SHEET 2
ZONE B-3
SEE TABLE II FOR PINOUT DETAILS

TABLE II (PoE CONNECTOR)	
CONNECTOR DESIGNATION	FUNCTION
J1.1	DATA PAIR 1
J1.2	DATA PAIR 1
J1.3	DATA PAIR 2
J1.4	+48-56VDC PoE POWER INPUT
J1.5	+48-56VDC PoE POWER INPUT
J1.6	DATA PAIR 2
J1.7	DC RETURN FOR PoE INPUT
J1.8	DC RETURN FOR PoE INPUT

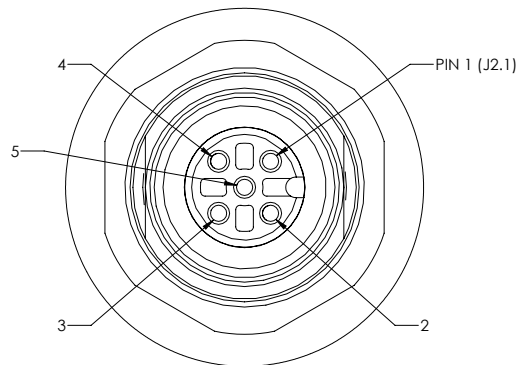

J2 CONNECTOR SHOWN FROM MATING SIDE
MATES WITH TURCK P/N - 8151-0/PG9

DETAIL C
SCALE 4 : 1
SHEET 2
ZONE B-7
SEE TABLE III FOR PINOUT DETAILS

TABLE III (SERIAL CONNECTOR)	
CONNECTOR DESIGNATION	FUNCTION
J2.1	DC RETURN FOR QPARUSA JOYSTICK
J2.2	NOT USED
J2.3	(B) TxD-/RxD- DATA LINE
J2.4	(A) TxD+/RxD+ DATA LINE
J2.5	DC POWER FOR QPARUSA JOYSTICK