

Transport Cases

Store, organize and transport all of your vital equipment safely and securely in our transport cases. Many of these cases have built-in wheels, ergonomic handles and stainless-steel hardware & padlock protectors. O-rings and automatic pressure equalization valves are part of almost every transport case.



Trusted for over 40 years by the US Military, Single Lid Cases offer 20% more protective material in the edges and corners, where it is needed most, ensuring that valuable equipment is kept safe from any unforeseen elements. Available in several sizes, these cases are completely customizable with a wide range of bolt-on options like document holders, casters, humidity indicators and much more.

- Molded-in, tongue-in-groove gasketed parting lines for splash resistance and tight seals, even after impact
- Reinforced corners and edges for additional impact protection
- Molded-in ribs and corrugations for secure, non-slip stacking, columnar strength, and added protection
- Recessed hardware for extra protection
- Positive anti-shear locks, which prevent lid separation after impact, and reduce stress on hardware
- Patented molded-in metal inserts for catch and hinge attachment points, which provide strength and spread loads to the container
- One-piece construction, molded from lightweight, high-impact polyethylene

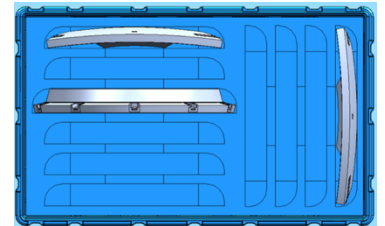
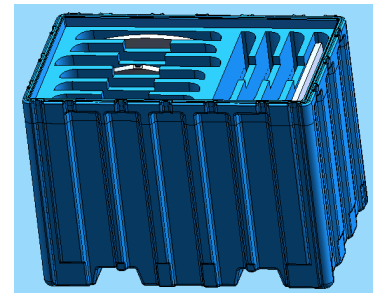

QLA272-1404AC Dual Unit



Exterior (LxWxD)

30.00 x 30.00 x 20.18 in

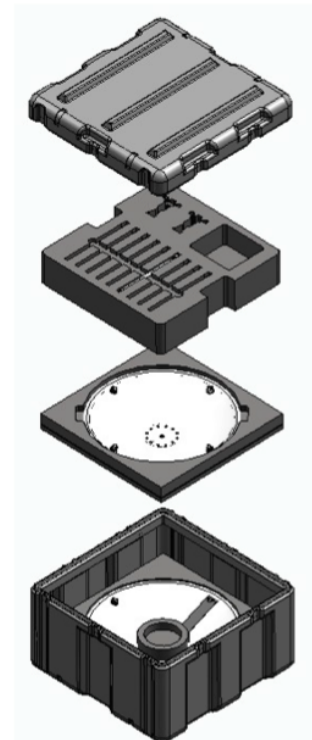

If you would like more information, or would like to discuss your unique application, please contact us today. We look forward to hearing from you.

sales@qparusa.com / www.qparusa.com
702-208-9973 / eFax: 702-208-9984
San Diego, CA 92020