

# QLA-C360MPS-10

AUTO ACQUISITION and TRACKING FOR MICROWAVE LOS

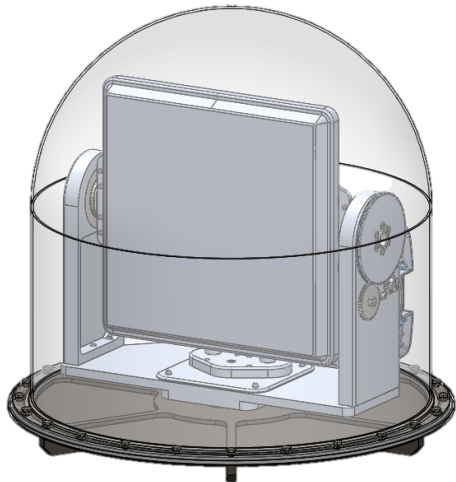

The QLA-C360MPS-10 is designed to auto acquire and actively maintain maritime Line of Sight communications for ship to ship or ship to shore point to point or point to multipoint networks.

The embedded antenna controller has a built in GPS, digital compass, and optional on board gyro stabilization. C360MPS can also accept external pitch and roll from available on board sensor suites. The web based user interface provides configuration and monitoring of the radio link. QPAR Antennas also has a command line interface for customers that want to add our solution into a larger system.

The QLA-C360MPT-10 has an integrated 5GHz unlicensed antenna and will accept many commercial Radio/ODU solutions available on the market today. QPAR Antennas can also deliver a complete solution integrated with a radio.

## TECHNICAL SPECIFICATIONS - QLA-C360MPS-10

Power	PoE 48VDC-56VDC @ 48 watts (Supply Included for positioner)
Material / Finish	Aluminum with stainless steel hardware / Hard coat anodize
Positioner Travel	
Azimuth	Continuous 360°
Elevation	110° (- 10° to +100°)
Positioner Velocity	
Azimuth	Velocity 25°/sec
Elevation	Velocity 25°/sec
Environmental	
Operational Temp	-22 to 140°F (-30 to 60°C)
Survival	-40 to 158°F (-40 to 70°C)
Size and Weight	
Weight	60 lbs (27.21 kg) without radio (Typical radio weight ~5lbs (2.23 kg))
Dimensions with Radome	Height: 23.5" (59.69 cm), Diameter: 24.5.00" (62.23 cm)
Antenna Details	
Gain	23.5dBi
3dB Beamwidth	7° Vertical and Horizontal
Frequency Range	4.9 - 5.875 GHz
Pass Through	
Radio Connector	Weather Tight RJ-45 for PoE connection to radio
Communication Interface	
User Interfaces	Web based hosted internal to unit or QPARUSA proprietary command protocol
Positioner Ethernet	10/100 Ethernet
Other	SNMP Interfaces for Acquisition and Tracking to most commercial radios

REV A

Specifications subject to change without notice

# QLA-C360MPS-10

## Size and Weight

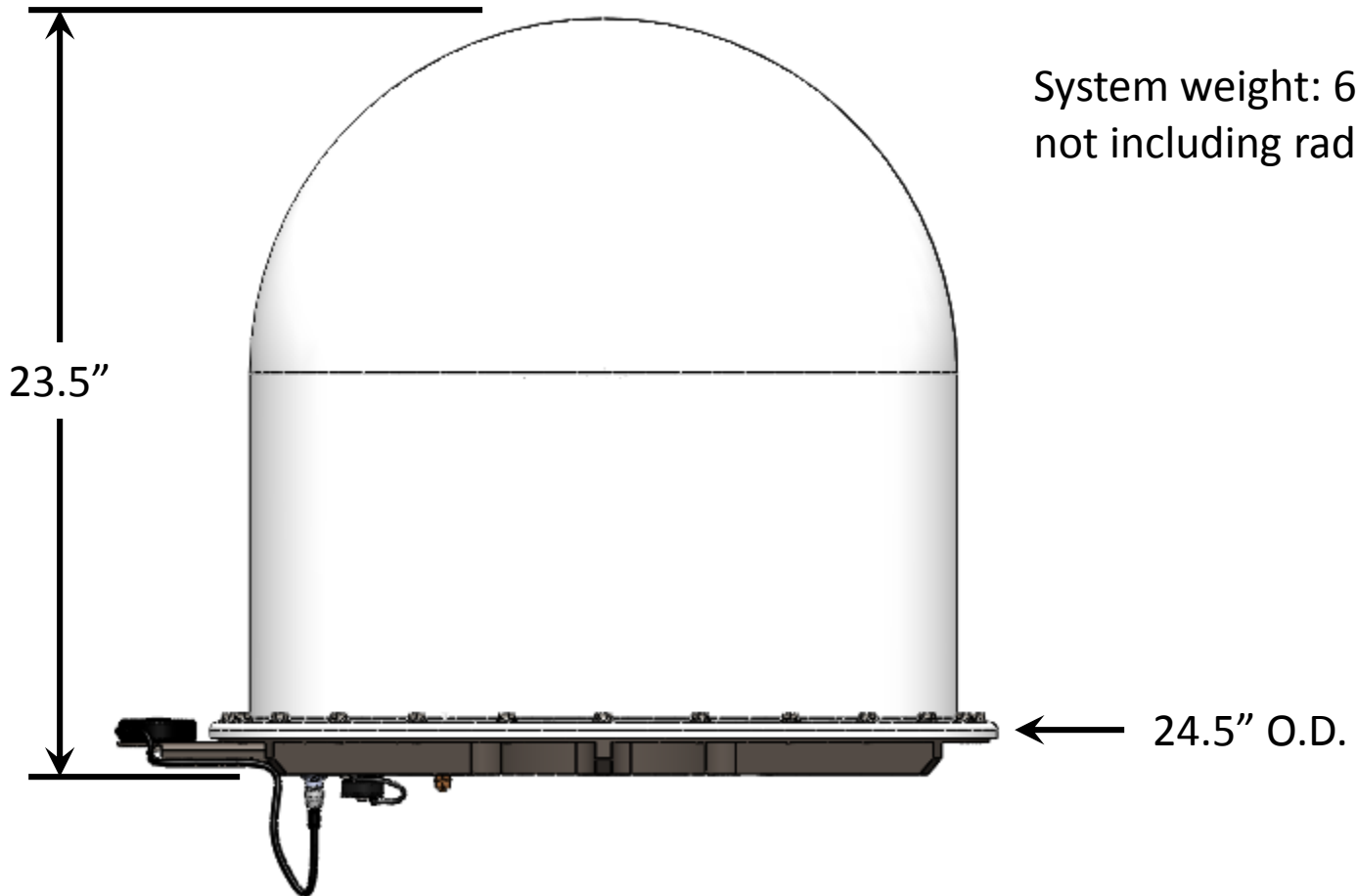

# QLA-C360MPS-10

## Other Specs

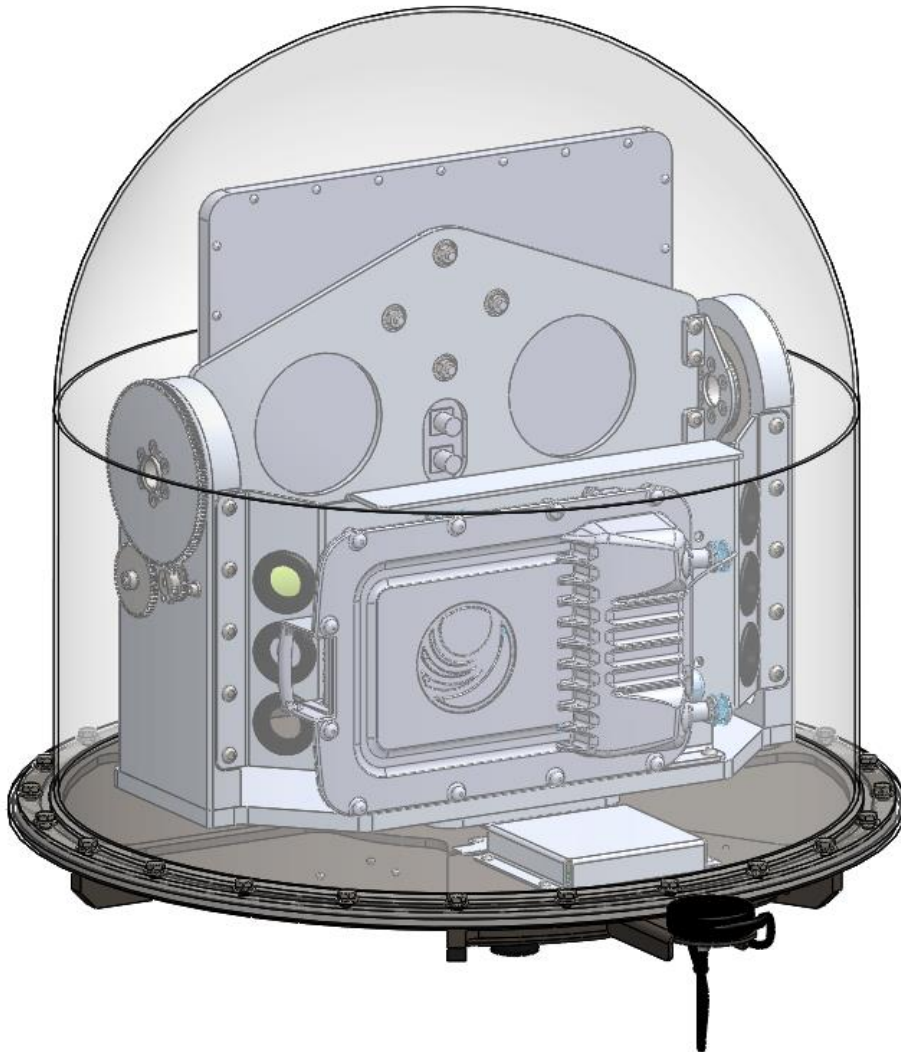

- Az/EI Drive Rate
  - 25 deg/s
- Azimuth Range of Motion
  - 360 deg continuous
- Elevation Range of Motion
  - -10 deg to 100 deg
- 48VDC PoE Operation

# QLA-C360MPS-10

## Auxiliary Views

