

REV	DESCRIPTION	DATE	APPROVED
C	CN600564	2018-07-26	CLC

NOTES: UNLESS OTHERWISE SPECIFIED

1. QPAR LINKALIGN-60EBP-20 CONFIGURABLE OPTIONS PER TABLE I. PART NUMBER QLA-60EBP-20-100-01 SHOWN THROUGHOUT THIS DRAWING. PoE CABLE SHOWN IS NOT TO SCALE
2. USE INTERFACE CONTROL DRAWING IN CONJUNCTION WITH DATASHEET N500133
3. 48 - 56VDC POWER SUPPLY INCLUDED WITH POSITIONER. NOT SHOWN IN DRAWING
4. HARD COAT ANODIZE ALUMINUM CONSTRUCTION WITH STAINLESS STEEL HARDWARE
5. 60° (+/-30°) AZIMUTH TRAVEL WITH 0.7°/SEC DRIVE RATE (NO LOAD)
6. 60° (+/-30°) ELEVATION TRAVEL WITH 0.7°/SEC DRIVE RATE (NO LOAD). POSITIONER CAN BE MOUNTED ON EITHER SIDE OF THE MAST. SOFTWARE FEATURES ALLOW FOR THE ELEVATION DIRECTION TO BE REVERSED
7. -22° TO 140°F (-30° TO 60°C) OPERATIONAL TEMPERATURE RANGE. -40 TO 158°F (-40 TO 70°C) NON-OPERATIONAL TEMPERATURE RANGE
8. 0.01° FEEDBACK RESOLUTION IN BOTH AXES
9. AZIMUTH AND ELEVATION BACKLASH LESS THAN 0.05°
10. ENVELOPE DIMENSIONS WHEN MOUNTED TO A 4.5" O.D. MAST ARE 16.86" (42.8 cm) HIGH X 11.50" (29.2 cm) WIDE X 13.29" (33.8 cm) DEEP. DIMENSIONS APPLY WHEN POSITIONER IS AT 0° AZIMUTH AND 0° ELEVATION ANGLES
11. WEIGHT APPROXIMATELY 51.0 LBS (23.0 kg) NOT INCLUDING PoE CABLE
12. CENTER OF GRAVITY 6.0" (15.2 cm) IN THE X-DIRECTION, 0.1" (0.3 cm) IN THE Y-DIRECTION AND 0.9" (2.3 cm) IN THE Z-DIRECTION FROM THE CORRESPONDING DATUM A, B, OR C
13. POSITIONER CLAMPS TO 3" - 4.5" OUTSIDE DIAMETER MAST (NOT INCLUDED), 4.5" O.D. MAST SHOWN THROUGHOUT THIS DRAWING
14. TORQUE THE INDICATED POSITIONER CLAMP FASTENERS (3/8-16 X 4.5" LONG STAINLESS STEEL HEX HEAD SCREWS) TO 236 IN-LBS OR 20 FT-LBS
15. PAYLOAD SHALL NOT EXCEED 200 LBS OR 150 FT-LBS OF OPERATIONAL TORQUE ABOUT THE AZIMUTH OR ELEVATION AXIS NOTED BY DATUM C AND B RESPECTIVELY
16. NON-OPERATIONAL WIND LOADING TORQUE SHALL NOT EXCEED 400 FT-LBS ON THE AZIMUTH OR ELEVATION AXIS NOTED BY DATUM C AND B RESPECTIVELY
17. ANTENNA MOUNTING PLATE VARIES TO SUPPORT ANTENNA PAYLOADS LISTED IN TABLE I. CUSTOM CONFIGURATIONS ARE ALSO AVAILABLE UPON REQUEST
18. TORQUE ANTENNA MOUNTING HARDWARE (5/16-18 X 1" LONG STAINLESS STEEL HEX HEAD SCREWS) TO 132 IN-LBS OR 11 FT-LB

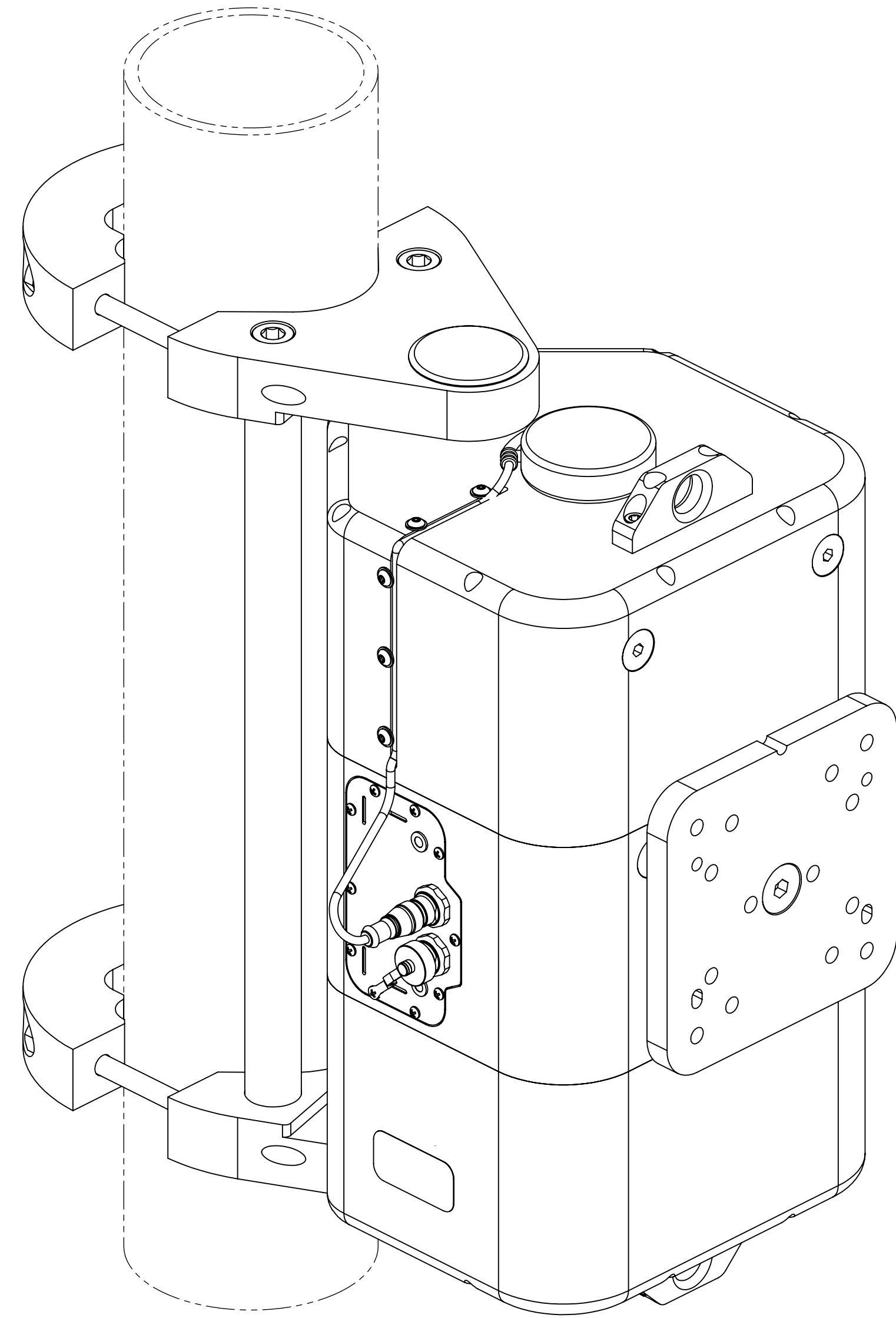

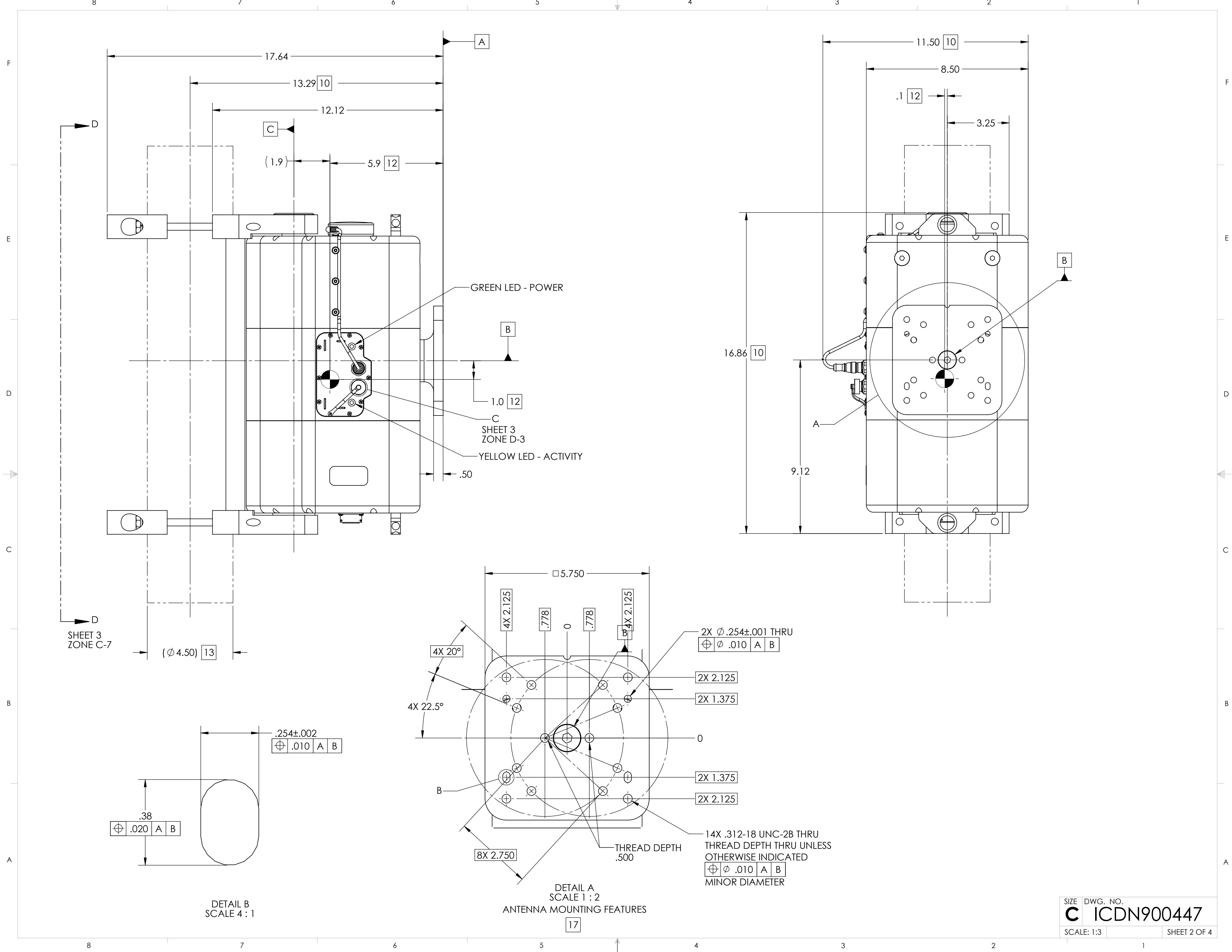

TABLE I	
BUILDING A PART NUMBER	STANDARD OPTIONS
LA-60EBP - 20 - 100	<<EXAMPLE
	SHIELDED ETHERNET CABLE STANDARD LENGTHS
	050 = 50 ft
	100 = 100 ft
	150 = 150 ft
	200 = 200 ft
	250 = 250 ft
	300 = 300 ft
	XXX = Custom length in feet
	XXXC = Add "C" to end of cable length for unterminated mating connector
	CUSTOM CONFIGURATION
	= Standard options - leave blank
	MOTOR DRIVES AND PAYLOAD
	20 = Az 150 ft-lbs @ 0.7°/s, El 150 ft-lbs @ 0.7°/s, 200 lb payload.
	Typically paired with 3 ft side arm mount antenna
	MODEL
	LA-60EBP = LinkAlign-60EBP (+/-30° azimuth, +/-30° elevation)

SYMBOL KEY <input type="checkbox"/> NOTE <input type="checkbox"/> PL ITEMS PROPRIETARY AND CONFIDENTIAL THE INFORMATION CONTAINED IN THIS DRAWING IS THE SOLE PROPERTY OF QPARUSA. ANY REPRODUCTION IN PART OR AS A WHOLE WITHOUT THE WRITTEN PERMISSION OF QPAR ANTENNAS USA IS PROHIBITED. QPAR ANTENNAS USA, LLC San Diego, CA 92020 www.qparusa.com	UNLESS OTHERWISE SPECIFIED: DIMENSIONS ARE IN INCHES TOLERANCES: ANGLE ± 5 DEGREES TWO PLACE DECIMAL ±.030 THREE PLACE DECIMAL ±.010 INTERPRET DIM AND TOL PER ASME Y14.5M - 1994 THIRD ANGLE PROJECTION  DO NOT SCALE DRAWING	DRAWN C. CHEYNE 2017-06-13 CHECKED S. CHEYNE 2017-06-13 ME APPR. S. CHEYNE 2017-06-13 EE APPR.	QPAR ANTENNAS USA, LLC TITLE: QPAR LINKALIGN-60EBP-20 INTERFACE CONTROL DRAWING
		PART NO. SEE TABLE I	SIZE DWG. NO. REV C ICDN900447 C
		SCALE: 1:2	SHEET 1 OF 4



SHEET 3
ZONE C-7

GREEN LED - POWER

YELLOW LED - ACTIVITY

SHEET 3
ZONE D-3

DETAIL B
SCALE 4 : 1

DETAIL A
SCALE 1 : 2
ANTENNA MOUNTING FEATURES

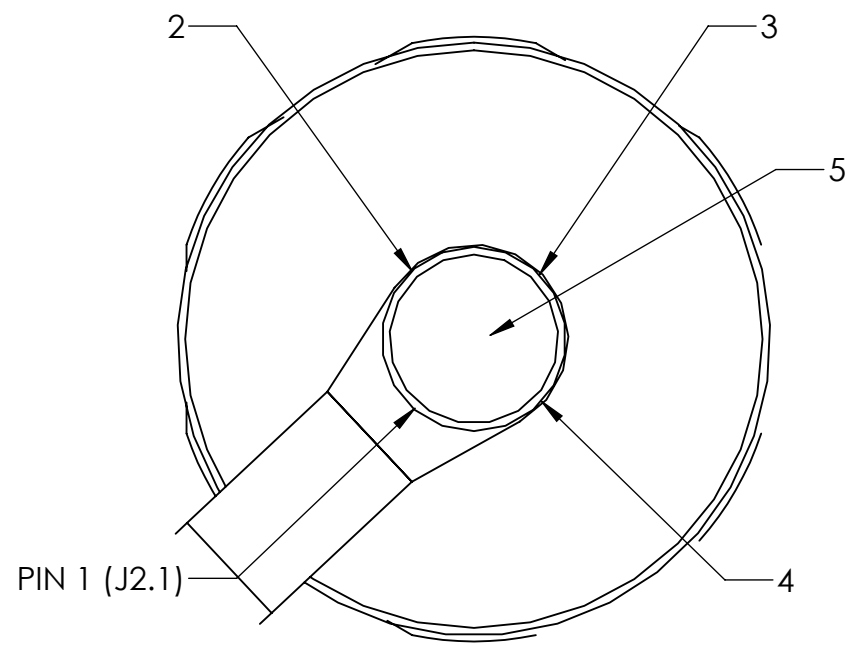
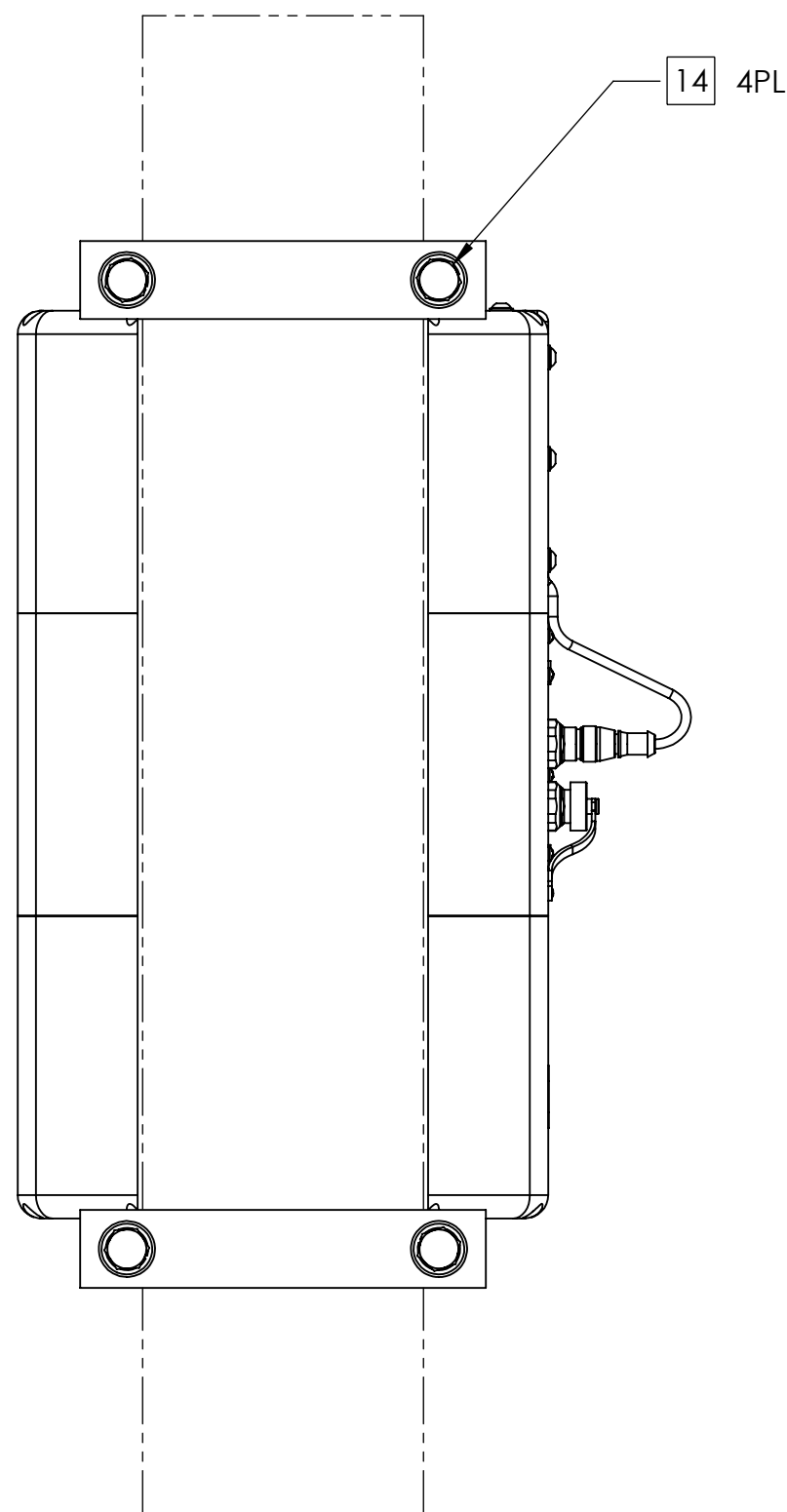

INTERCONNECT FOR SERIAL/OPTIONAL PELCO-D JOYSTICK INTERFACE

J2 CONNECTOR SHOWN FROM MATING SIDE
 MATES WITH TURCK P/N 8151-0/PG9
 CONNECTOR DUST CAP NOT SHOWN

DETAIL C
 SCALE 4 : 1
 SHEET 2
 ZONE D-5
 SEE TABLE III FOR PINOUT DETAILS

TABLE III (SERIAL CONNECTOR)	
CONNECTOR DESIGNATION	FUNCTION
J2.1	DC RETURN FOR QPARUSA JOYSTICK
J2.2	NOT USED
J2.3	(B) TxD-/RxD- DATA LINE
J2.4	(A) TxD+/RxD+ DATA LINE
J2.5	DC POWER FOR QPARUSA JOYSTICK

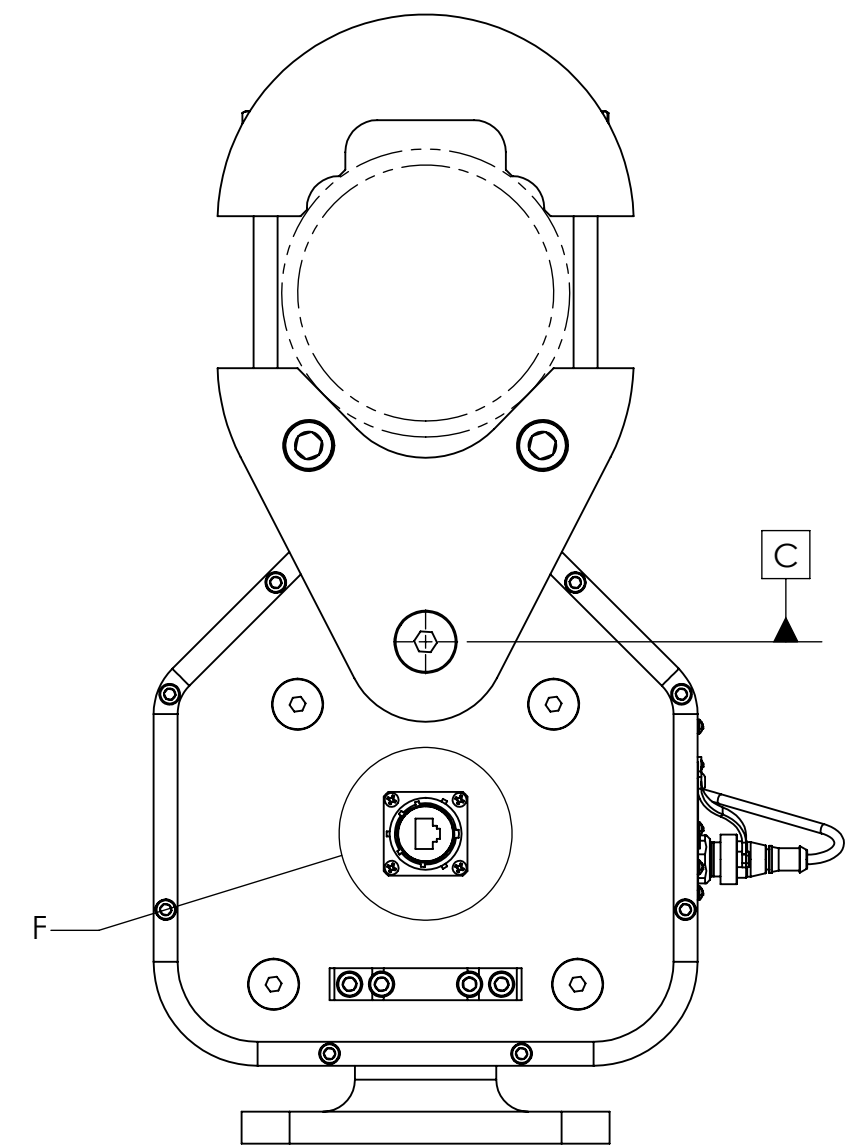

VIEW E-E

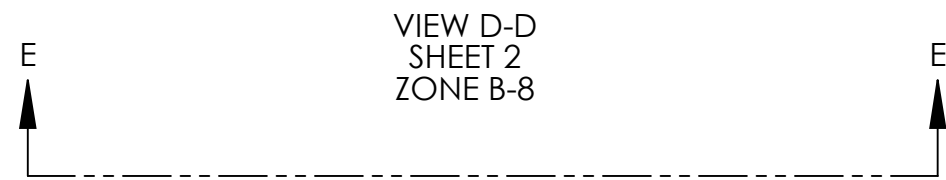

VIEW D-D
 SHEET 2
 ZONE B-8

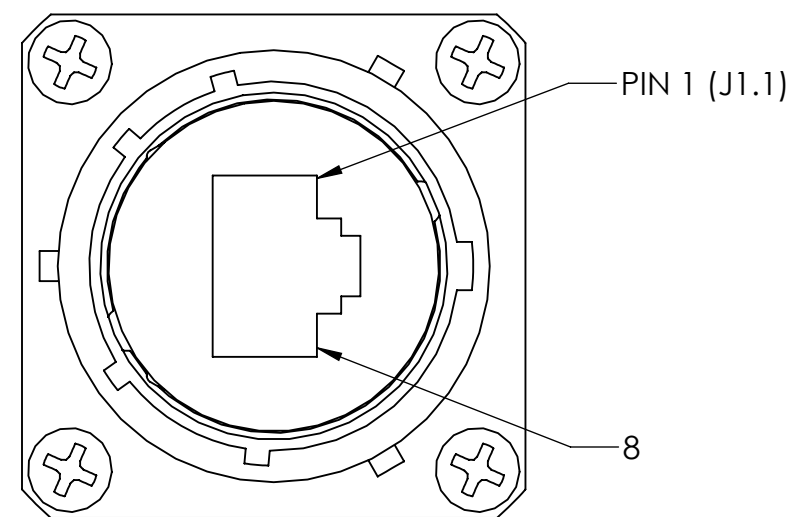

INTERCONNECT FOR POSITIONER PoE

J1 CONNECTOR SHOWN FROM MATING SIDE
 MATES WITH AMPHENOL P/N - RJF6B

DETAIL F
 SCALE 2 : 1
 SEE TABLE II FOR PINOUT DETAILS

TABLE II (PoE CONNECTOR)	
CONNECTOR DESIGNATION	FUNCTION
J1.1	DATA PAIR 1
J1.2	DATA PAIR 1
J1.3	DATA PAIR 2
J1.4	+48-56VDC PoE POWER INPUT
J1.5	+48-56VDC PoE POWER INPUT
J1.6	DATA PAIR 2
J1.7	DC RETURN FOR PoE INPUT
J1.8	DC RETURN FOR PoE INPUT

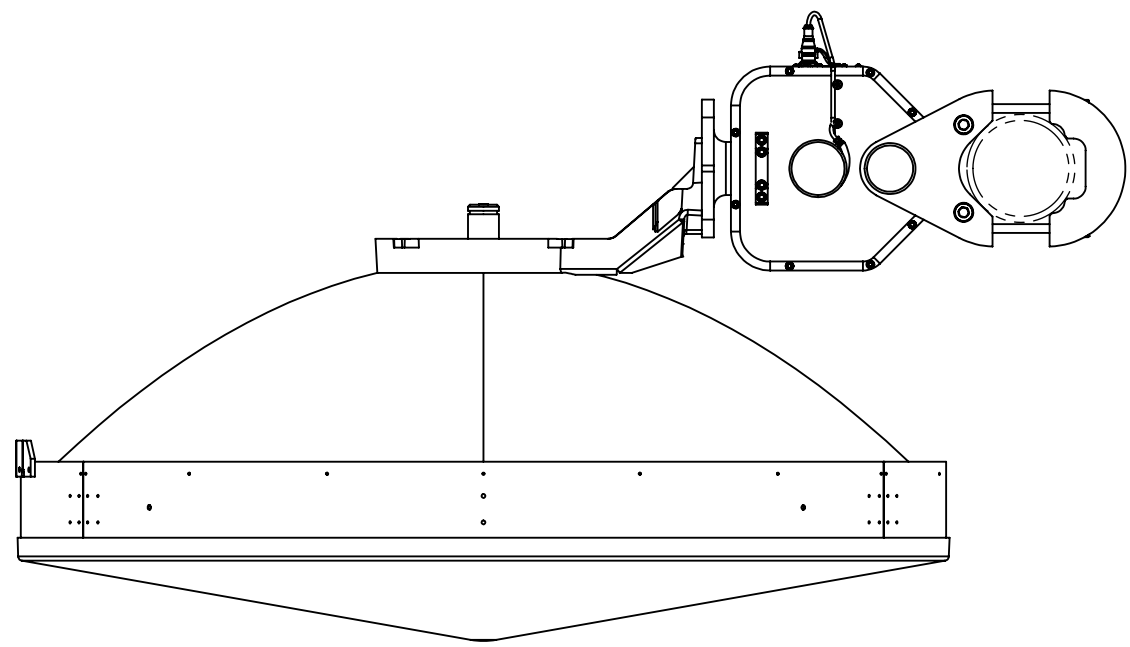

DEFAULT ELEVATION ORIENTATION 6

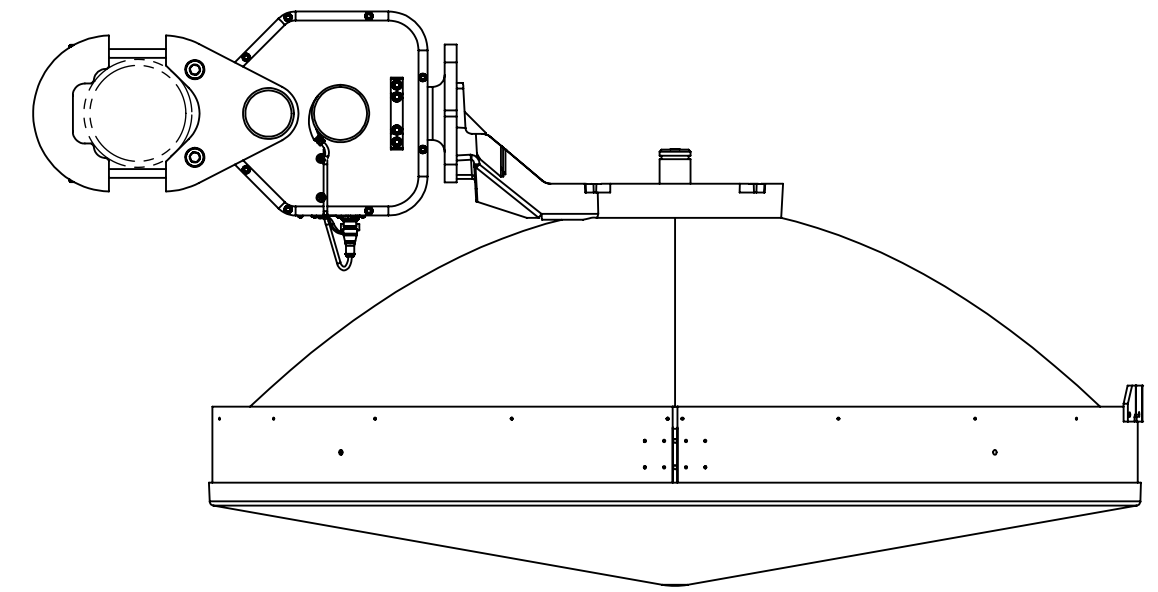

REVERSE ELEVATION ORIENTATION 6

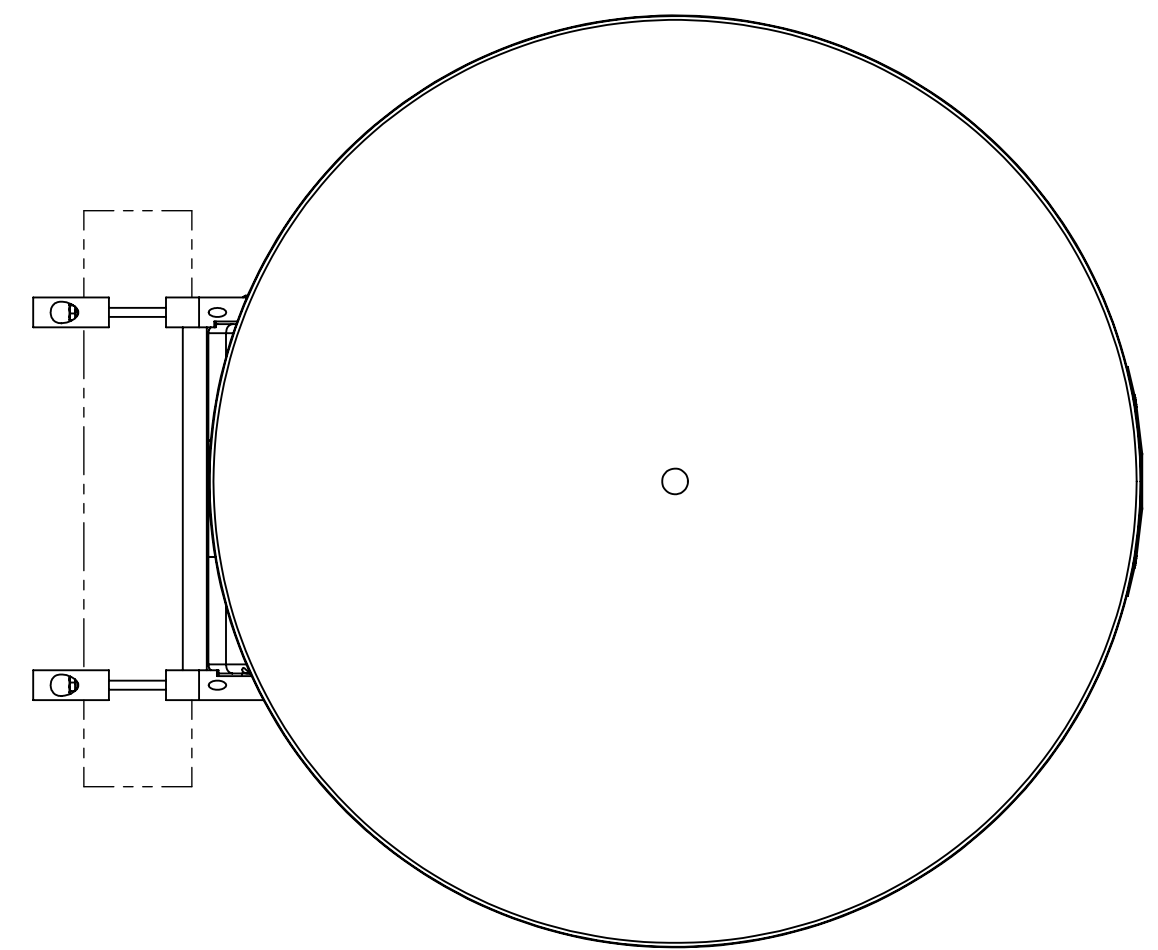
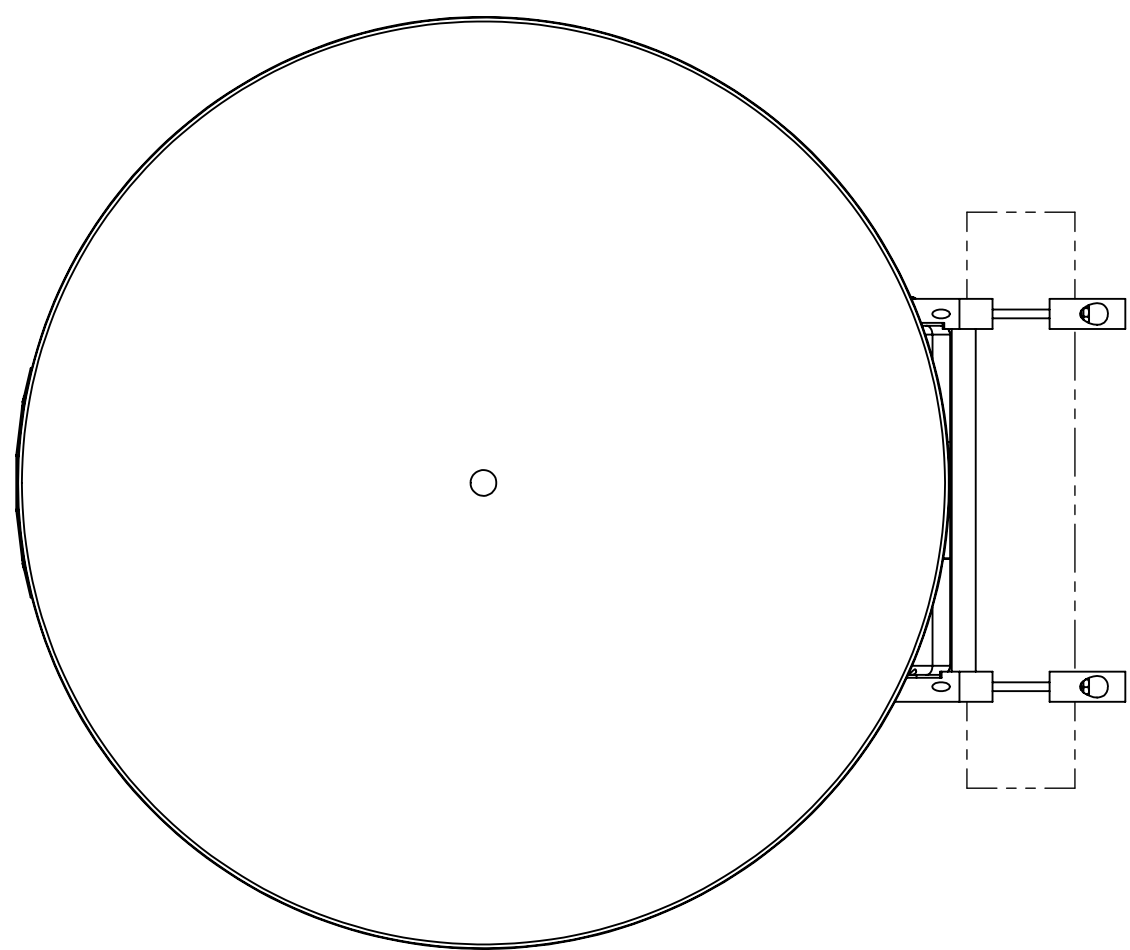

mWAVE HRP2-800 SHOWN FOR REFERENCE ONLY