

REV	DESCRIPTION	DATE	APPROVED
A	IR800701	2021-03-30	CLC

NOTES: UNLESS OTHERWISE SPECIFIED

1. QLA-360MPT-30 CONFIGURABLE OPTIONS PER TABLE I
2. USE INTERFACE CONTROL DRAWING IN CONJUNCTION WITH DATASHEET N500191
3. SEE TABLE II FOR AVAILABLE QLA-360MPT-30 ACCESSORY OPTIONS
4. POSITIONER POWERED BY POWER OVER ETHERNET 50-57 VDC, 4 PAIR, PoH (INDOOR RATED 54 VDC POWER SUPPLY INCLUDED WITH POSITIONER. NOT SHOWN IN DRAWING). OPTIONAL DC POWER INPUT MAY BE USED AS ALTERNATE CUSTOM CONFIGURATION, 20-60 V. STANDBY POWER DRAWS LESS THAN 16 W. MAXIMUM POWER DRAW, 95 W
5. EXTERNAL CONSTRUCTION COMPRISED OF HARD COAT ANODIZE ALUMINUM WITH STAINLESS STEEL HARDWARE
6. 540° (+/-270°) AZIMUTH TRAVEL WITH UPT TO 16°/SEC DRIVE RATE (MAX LOAD)
7. 190° (+/-95°) ELEVATION TRAVEL WITH UP TO 5°/SEC DRIVE RATE (MAX LOAD)
8. -22° TO 140°F (-30° TO 60°C) OPERATIONAL TEMPERATURE RANGE. -40° TO 158°F (-40 TO 70°C) NON-OPERATIONAL TEMPERATURE RANGE
9. 0.01° FEEDBACK RESOLUTION
10. AZIMUTH AND ELEVATION BACKLASH LESS THAN 0.1°
11. 13.50" (34.3 cm) HIGH X 14.46" (36.7 cm) WIDE X 8.25" (21.0 cm) DEEP. DIMENSIONS APPLY WHEN POSITIONER IS AT 0° AZIMUTH AND 0° ELEVATION ANGLES
12. WEIGHT APPROXIMATELY 40.5 LBS (18.4 kg)
13. PAYLOAD NOT TO EXCEED 100 LBS (45.4 kg) OR 55 FT-LBS (75 Nm) OF TORQUE ABOUT THE ELEVATION AXIS. TO CALCULATE TORQUE, TAKE THE DISTANCE FROM THE PAYLOAD CENTER OF GRAVITY TO DATUM -B- IN FEET AND MULTIPLY BY THE PAYLOAD WEIGHT. MAXIMUM OPERATING TORQUE MAY BE REDUCED AT TEMPERATURES BELOW 5°F (-15°C) AND/OR WITH PERIPHERAL DEVICES
14. TABLE TOP MOUNTING HOLES
15. CENTER OF GRAVITY 0.2" (0.5 cm) IN THE X-DIRECTION, 6.2" (15.7cm) IN THE Y-DIRECTION AND 0" (0 cm) IN THE Z-DIRECTION
16. STANDARD PASS THRU CONNECTORS USE DC-3 GHz RF, 20" (50 cm) INTERNAL LENGTH
17. OPTIONAL SIGNAL PASS THRU CONNECTORS USE 39" (100 cm) INTERNAL LENGTH, 24 AWG WIRE ABLE TO CARRY 60 VAC / 75 VDC, 2A

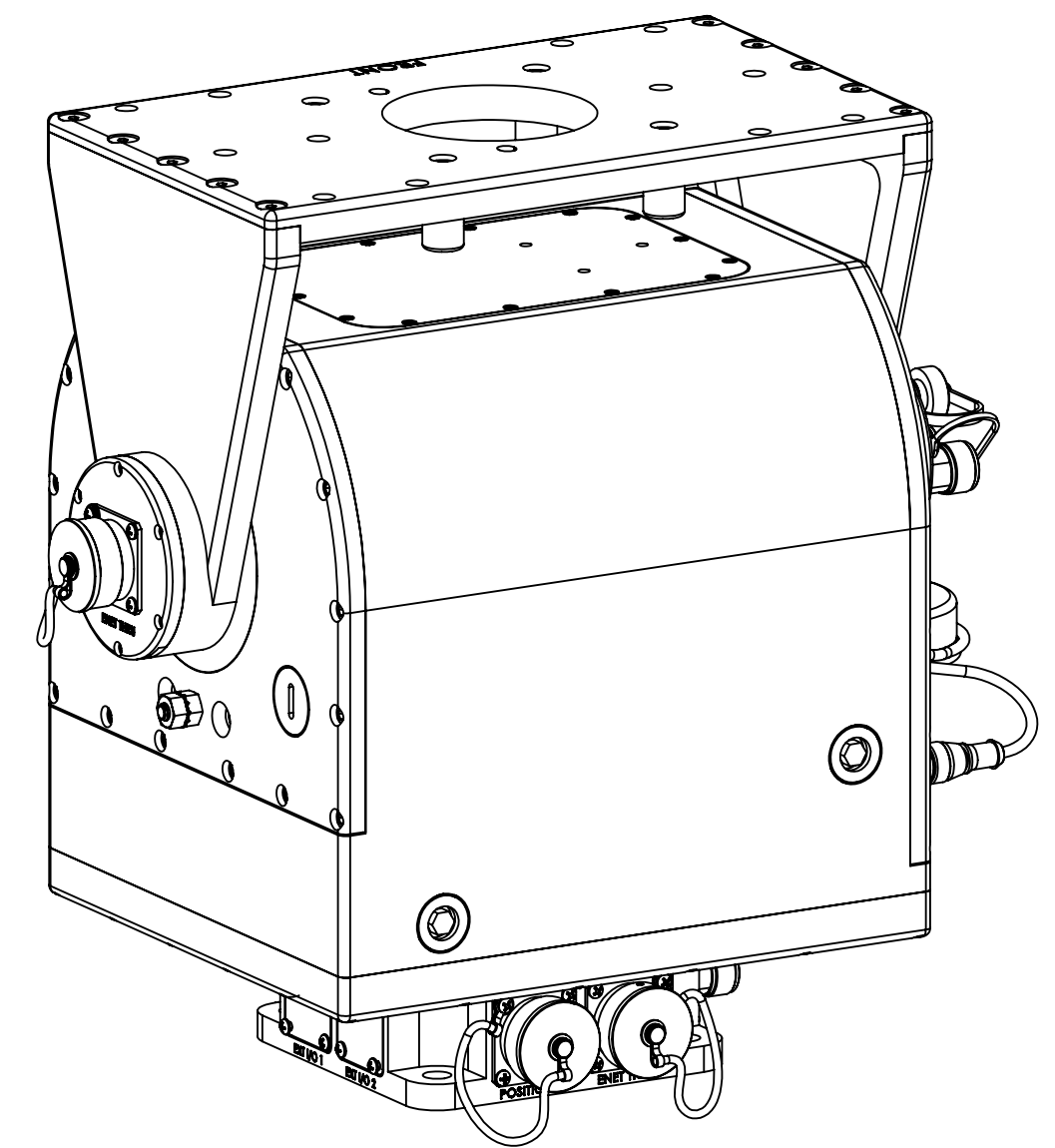
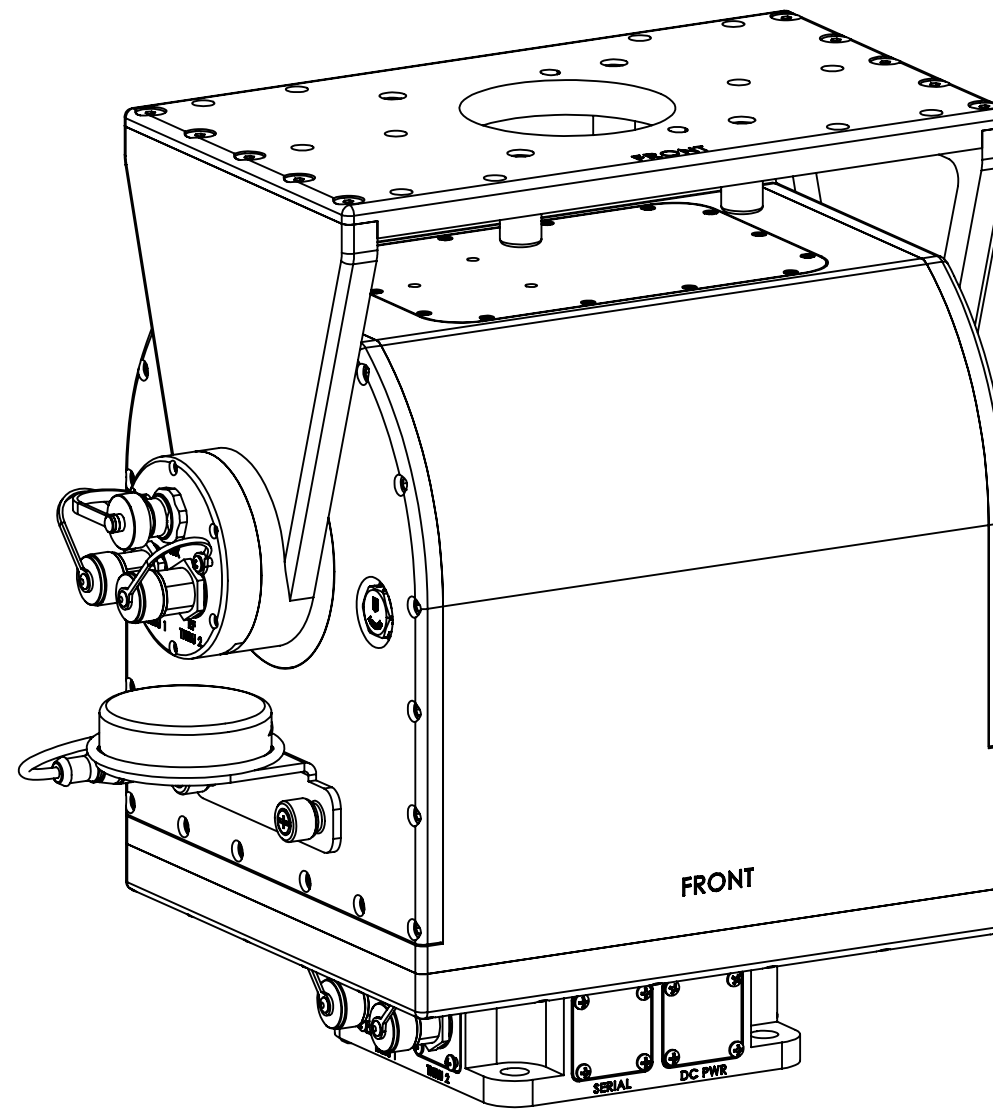
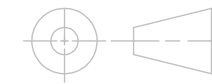
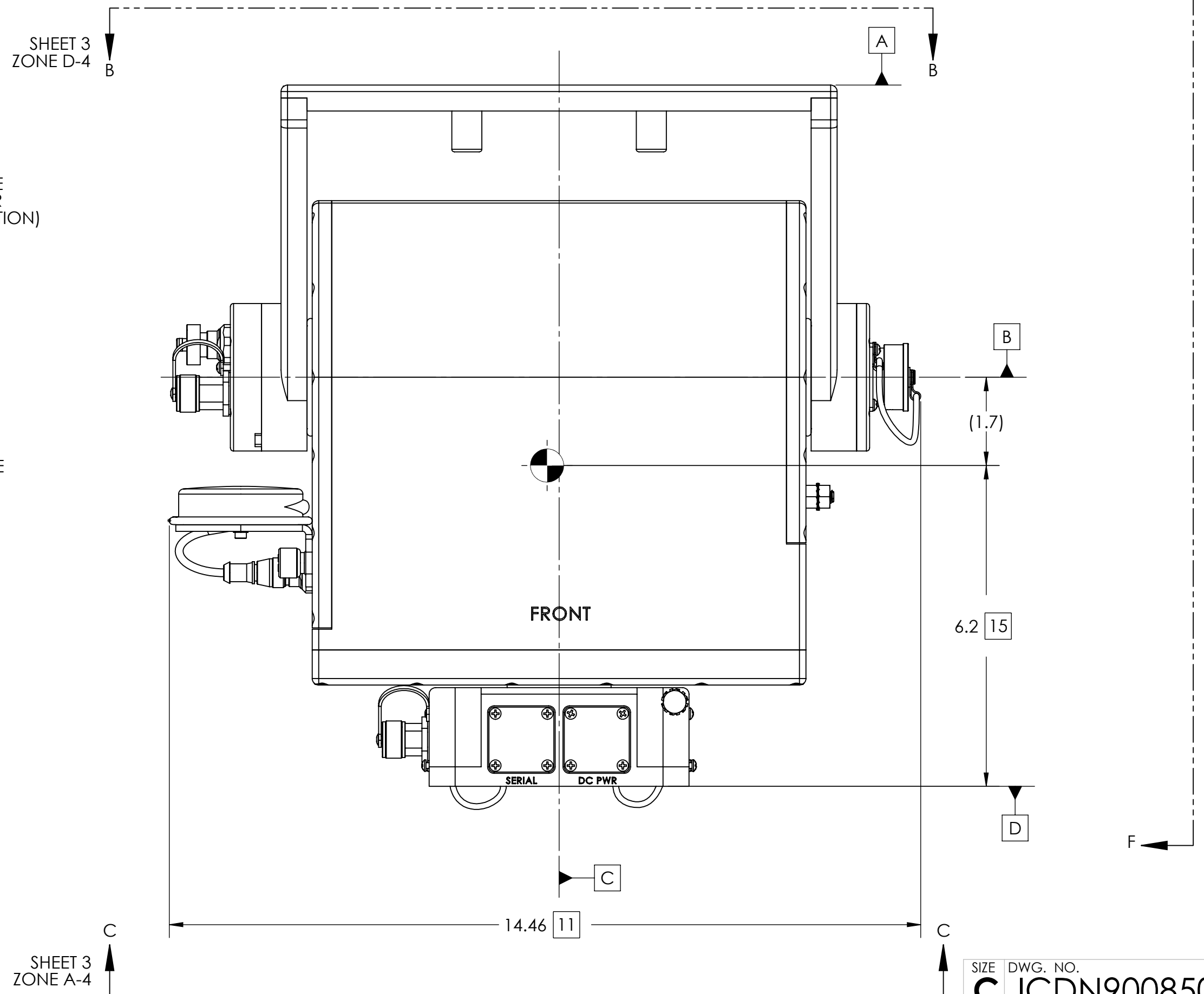
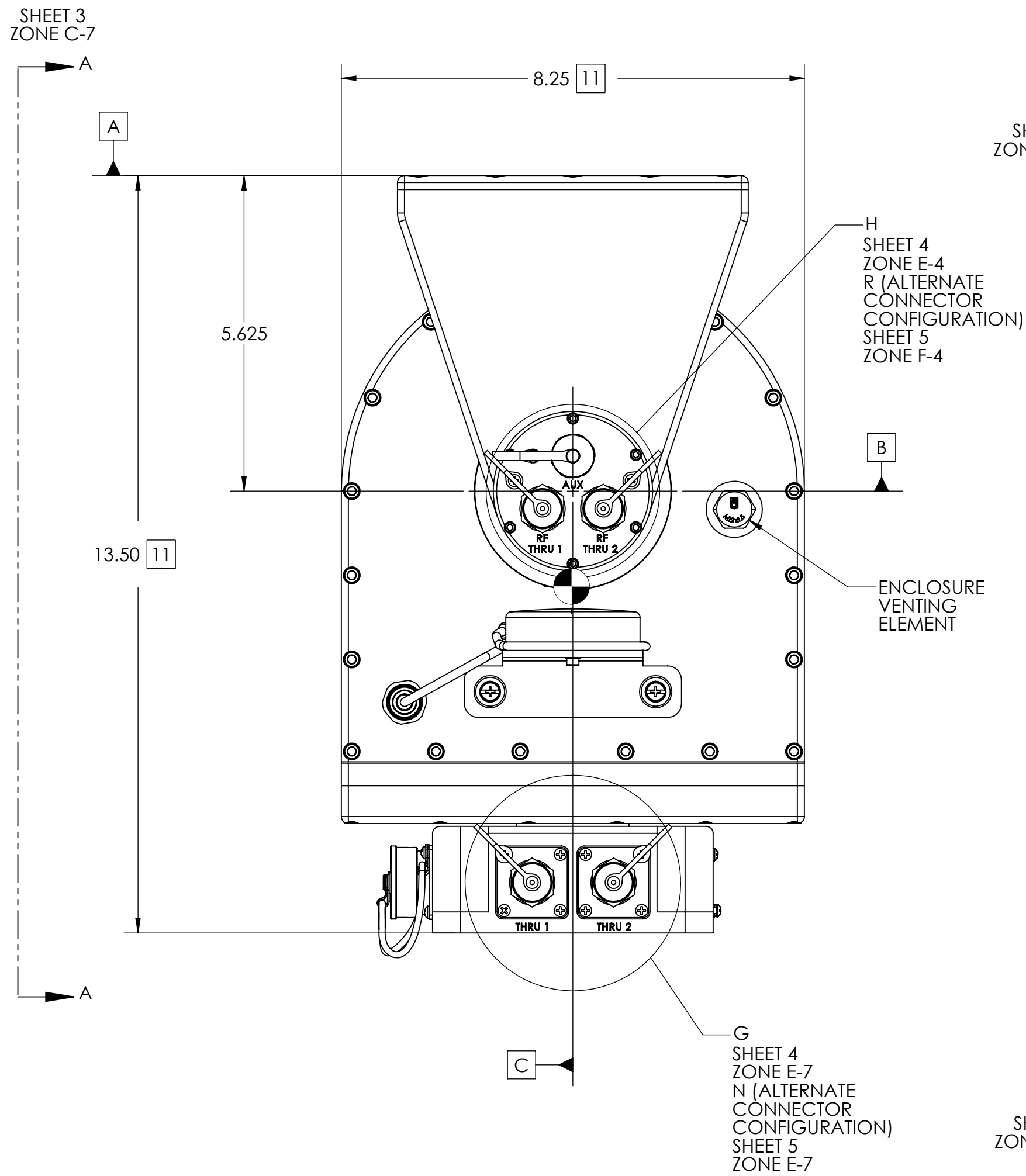
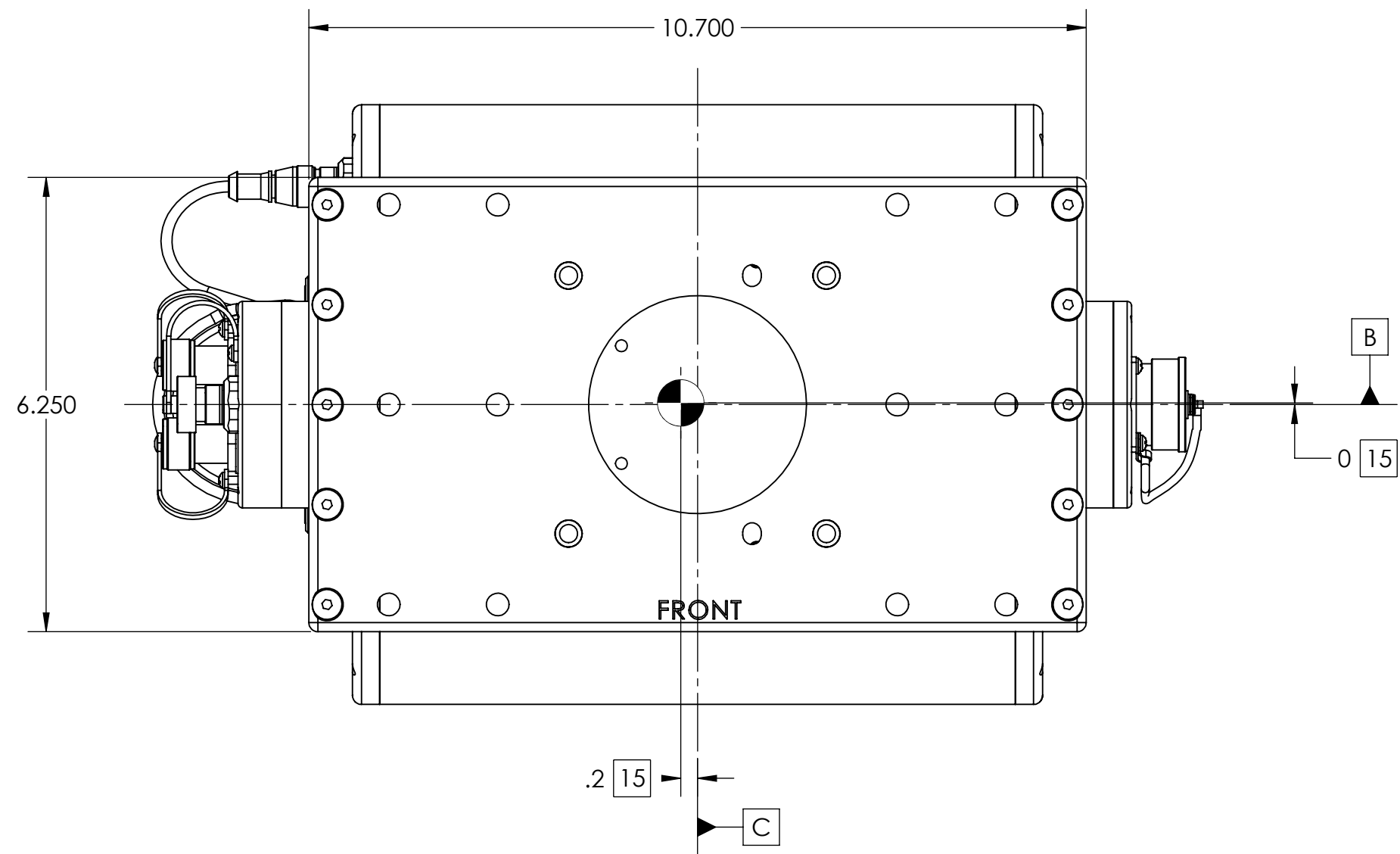
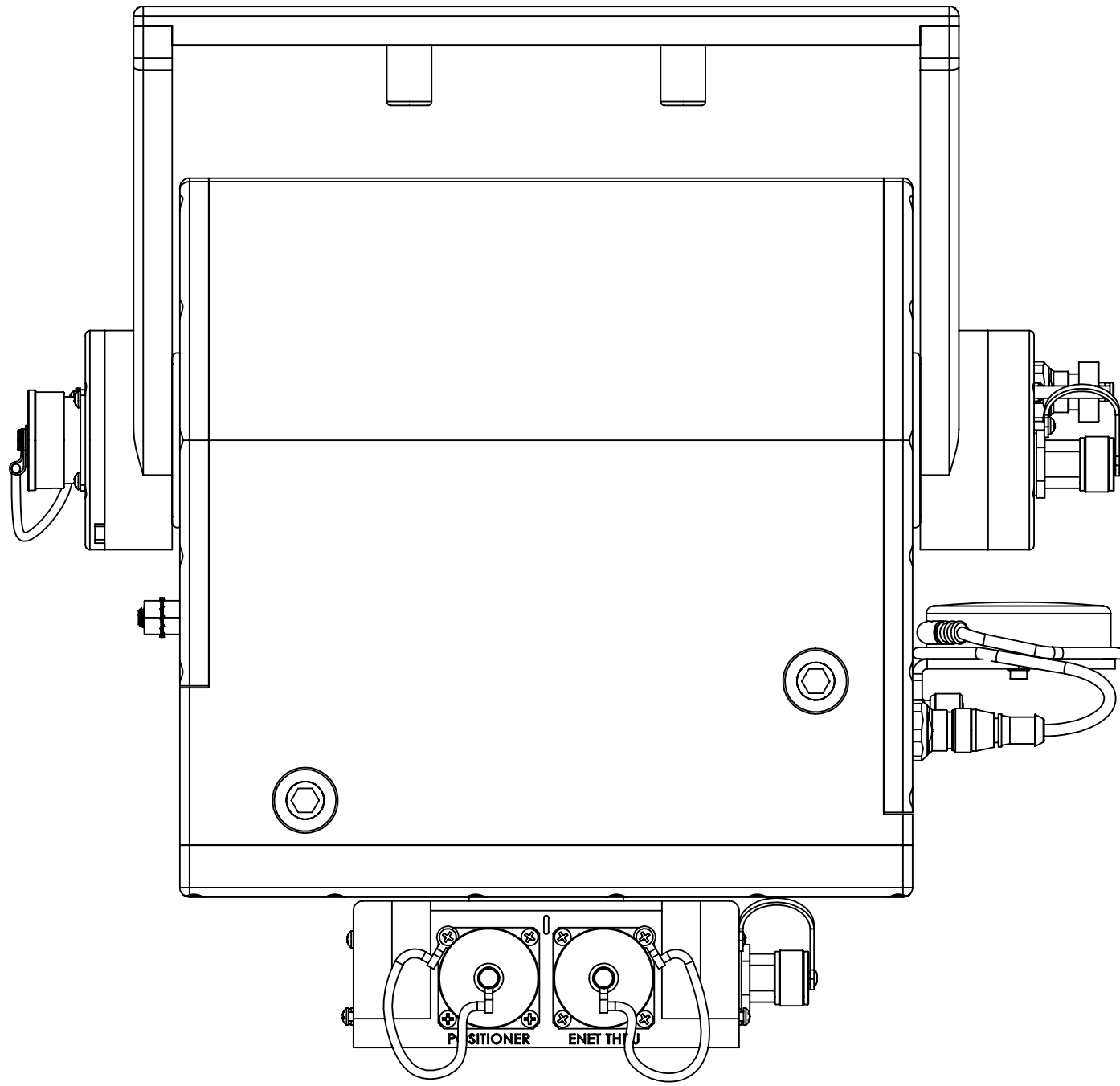

TABLE I	
BUILDING A PART NUMBER	STANDARD OPTIONS
LA-360MPT - 30 - - 100	<<EXAMPLE
	SHIELDED ETHERNET CABLE STANDARD LENGTHS
	050 = 50 ft
	100 = 100 ft
	150 = 150 ft
	200 = 200 ft
	250 = 250 ft
	300 = 300 ft
	XXX = Custom length in feet
	XXXC = Add "C" to end of cable length for unterminated mating connector
	CUSTOM CONFIGURATION
	= Standard options - leave blank
	MOTOR DRIVES AND PAYLOAD
	30 = Az Travel @ 16°/s, EL Travel @ 5°/s, El torque 55 ft-lbs, 100 lb payload. Typically paired with 2-3 ft antennas
	MODEL
	LA-360MPT = LinkAlign-360MPT (+/-270° azimuth, +/-95° elevation)

TABLE II (ACCESSORY OPTIONS)		
ACCESSORY DESCRIPTION	ACCESSORY PART NUMBER	ACCESSORY ICD
QLA-360POL-10 POLARIZATION POSITIONER	QLA-360POL-10-X	ICDN900387
QUICKMOUNT 2 INCH OD MAST ADAPTER	QACC-N900728-1	ICDN900728
TRIPOD ASSEMBLY, LIGHTWEIGHT, FOLDING, 2 INCH OD MAST	QACC-N900320-1	ICDN900320
TRIPOD ASSEMBLY, HEAVY DUTY, 2 INCH OD MAST	QACC-N900413-1	ICDN900413
TRIPOD ASSEMBLY, LIGHTWEIGHT, 2 INCH OD MAST	QACC-N900868-1	ICDN900868
QUADPOD ASSEMBLY, LIGHTWEIGHT, 2 INCH OD MAST	QACC-N900869-1	ICDN900869

SYMBOL KEY <input type="checkbox"/> NOTE <input type="checkbox"/> PL ITEMS PROPRIETARY AND CONFIDENTIAL THE INFORMATION CONTAINED IN THIS DRAWING IS THE SOLE PROPERTY OF Q-PAR Antennas USA, LLC. ANY REPRODUCTION IN PART OR AS A WHOLE WITHOUT THE WRITTEN PERMISSION OF Q-PAR Antennas USA, LLC IS PROHIBITED. Q-PAR Antennas USA, LLC Las Vegas, NV 89121 www.qparusa.com	UNLESS OTHERWISE SPECIFIED: DIMENSIONS ARE IN INCHES TOLERANCES: ANGLE ± 5 DEGREES TWO PLACE DECIMAL ±.030 THREE PLACE DECIMAL ±.010 INTERPRET DIM AND TOL PER ASME Y14.5M - 1994 THIRD ANGLE PROJECTION  DO NOT SCALE DRAWING	DRAWN C. CHEYNE 2021-03-30 CHECKED S. CHEYNE 2021-03-30 ME APPR. C. CHEYNE 2021-03-30 EE APPR.	Q-PAR Antennas USA, LLC TITLE: INTERFACE CONTROL DRAWING, QLA-360MPT-30 PART NO. SEE TABLE I SCALE: 3:8	SIZE DWG. NO. C ICDN900850 REV A SHEET 1 OF 5
		Q-PAR Antennas USA, LLC Las Vegas, NV 89121 www.qparusa.com	DRAWN C. CHEYNE 2021-03-30 CHECKED S. CHEYNE 2021-03-30 ME APPR. C. CHEYNE 2021-03-30 EE APPR.	Q-PAR Antennas USA, LLC TITLE: INTERFACE CONTROL DRAWING, QLA-360MPT-30 PART NO. SEE TABLE I SCALE: 3:8





VIEW A-A
SCALE 1 : 2
SHEET 2
ZONE D-8

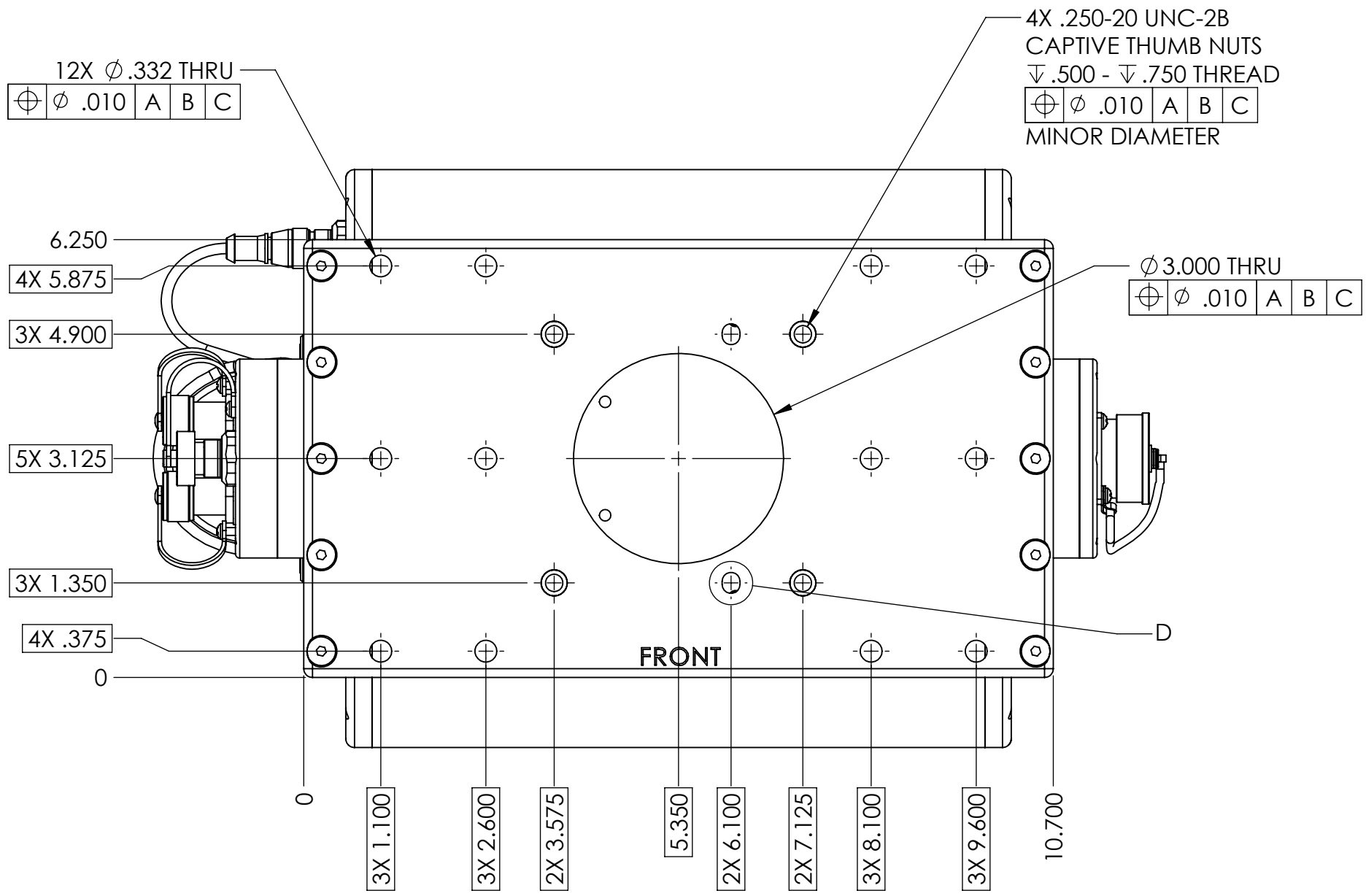

VIEW B-B
SCALE 1 : 2
SHEET 2
ZONE D-5

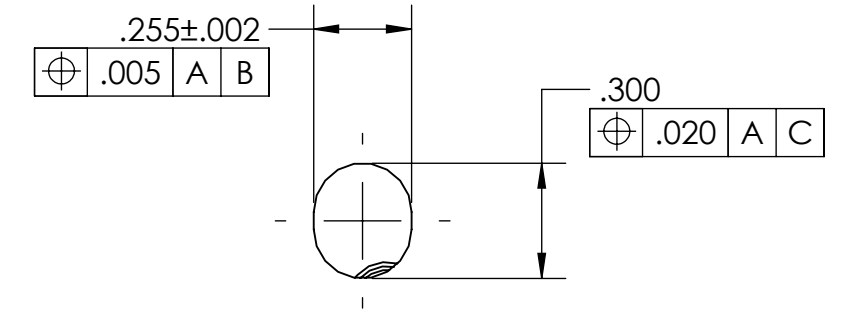

DETAIL D
SCALE 2 : 1
2 PLACES

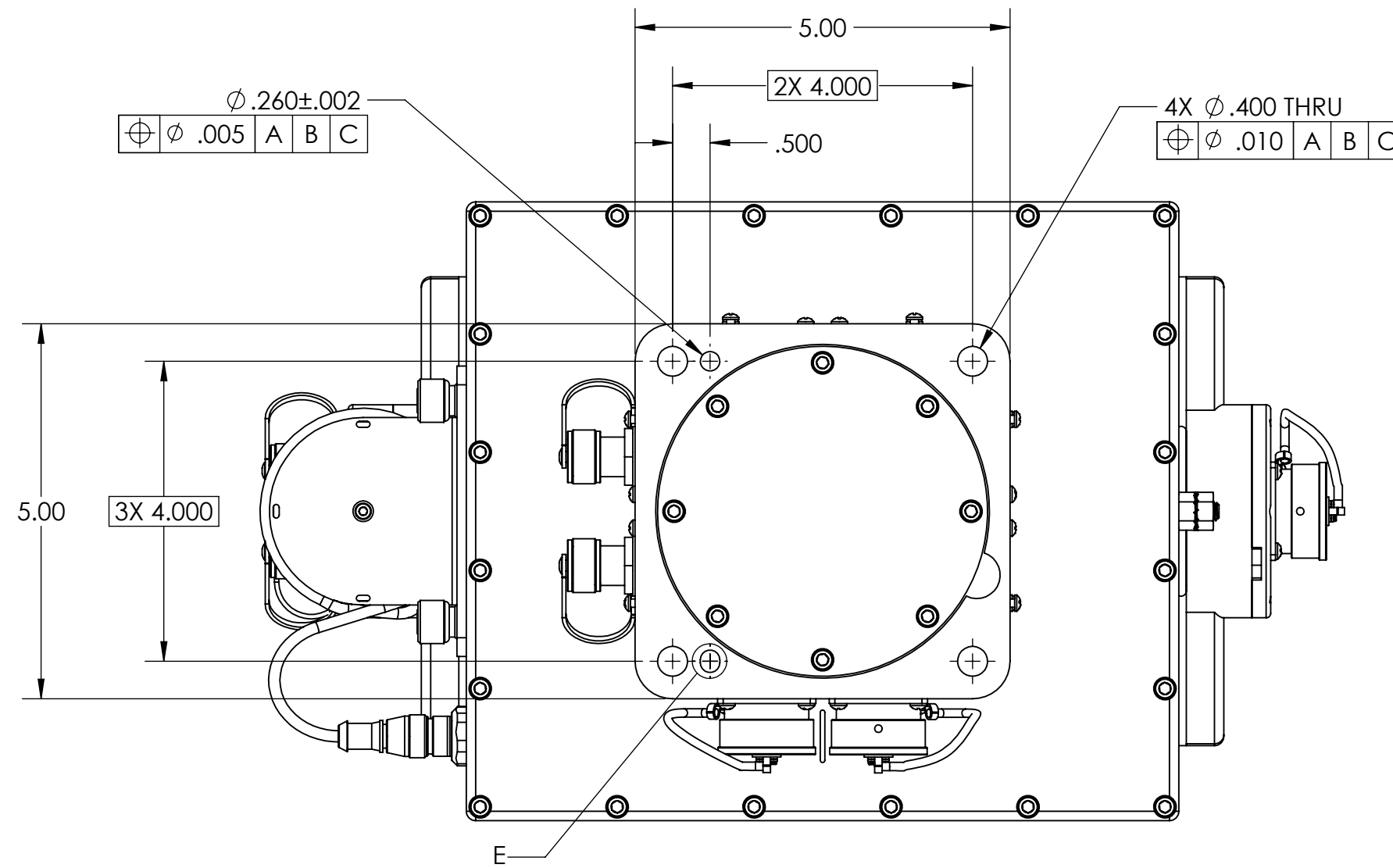

VIEW C-C
SCALE 1 : 2
SHEET 2
ZONE A-5
TABLE TOP MOUNTING HOLES

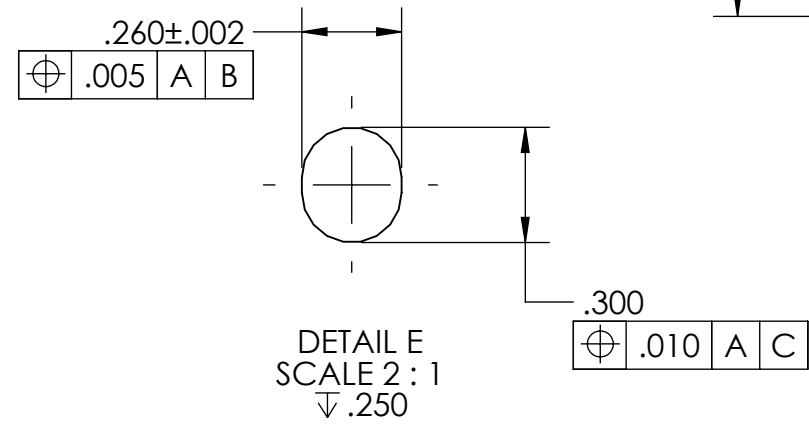

DETAIL E
SCALE 2 : 1
Ø.250

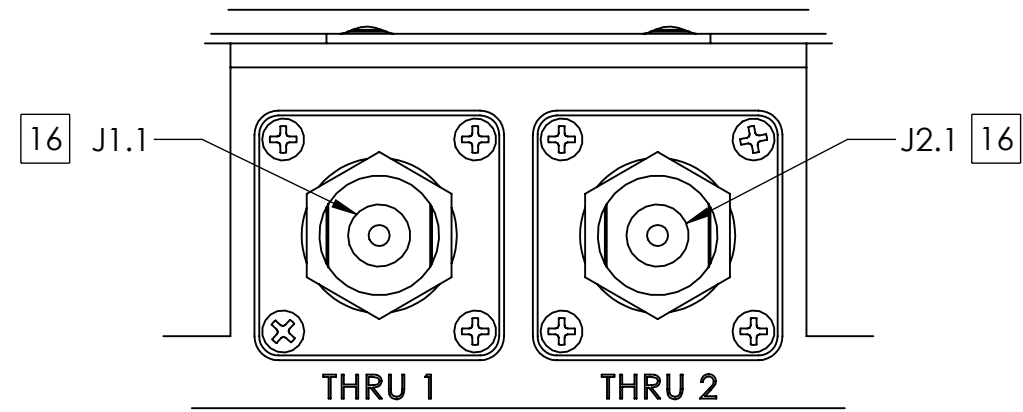

DETAIL G
SCALE 1 : 1
SHEET 2 ZONE A-6

SHOWN WITHOUT PROTECTIVE CAPS
SEE TABLE V FOR STANDARD CONNECTOR PINOUT DETAILS
SEE SHEET 5 DETAIL N ZONE E-7 FOR
ALTERNATE CONNECTOR CONFIGURATIONS

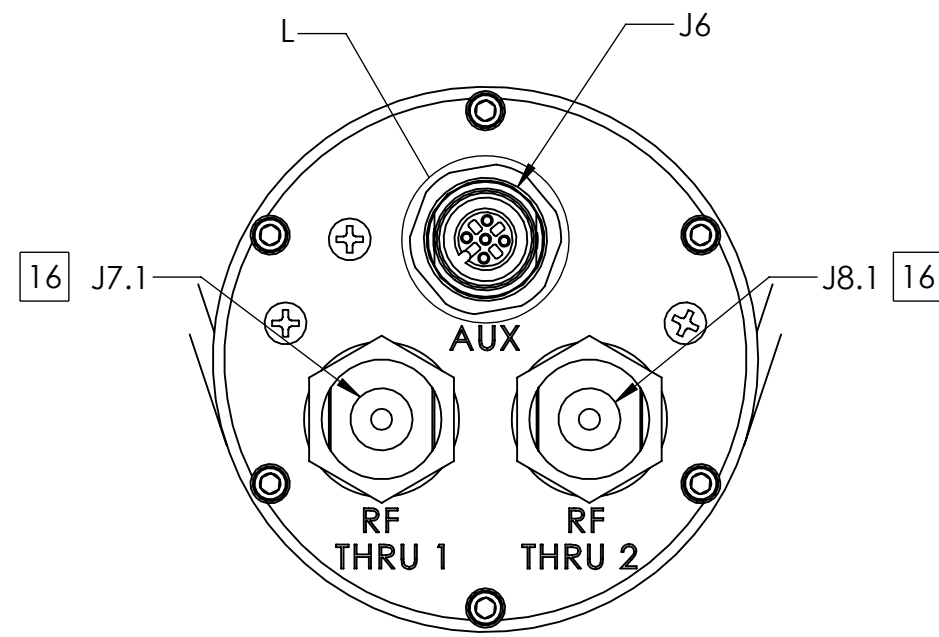

DETAIL H
SCALE 1 : 1
SHEET 2 ZONE C-5

SHOWN WITHOUT PROTECTIVE CAPS
SEE TABLE V FOR STANDARD CONNECTOR PINOUT DETAILS
SEE SHEET 5 DETAIL T ZONE E-4 FOR ALTERNATE
CONNECTOR CONFIGURATIONS

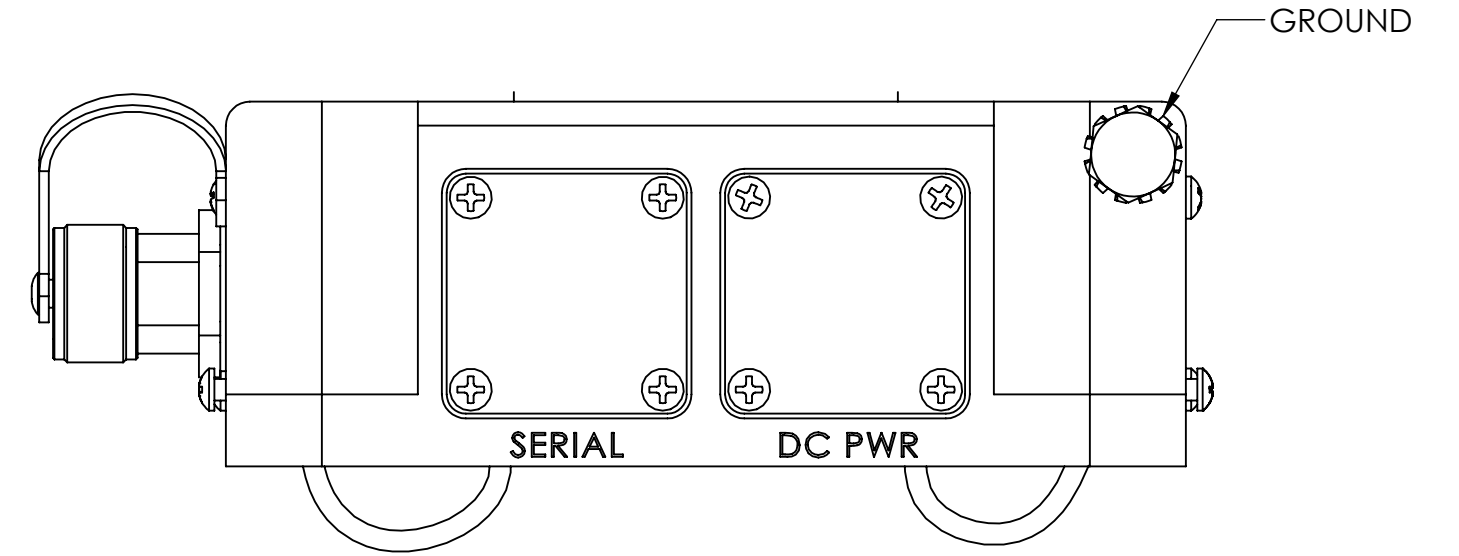

VIEW J-J
SCALE 1 : 1

STANDARD CONFIGURATION - NO CONNECTORS
SEE SHEET 5 VIEW R ZONE A-7 FOR ALTERNATE
CONNECTOR CONFIGURATIONS

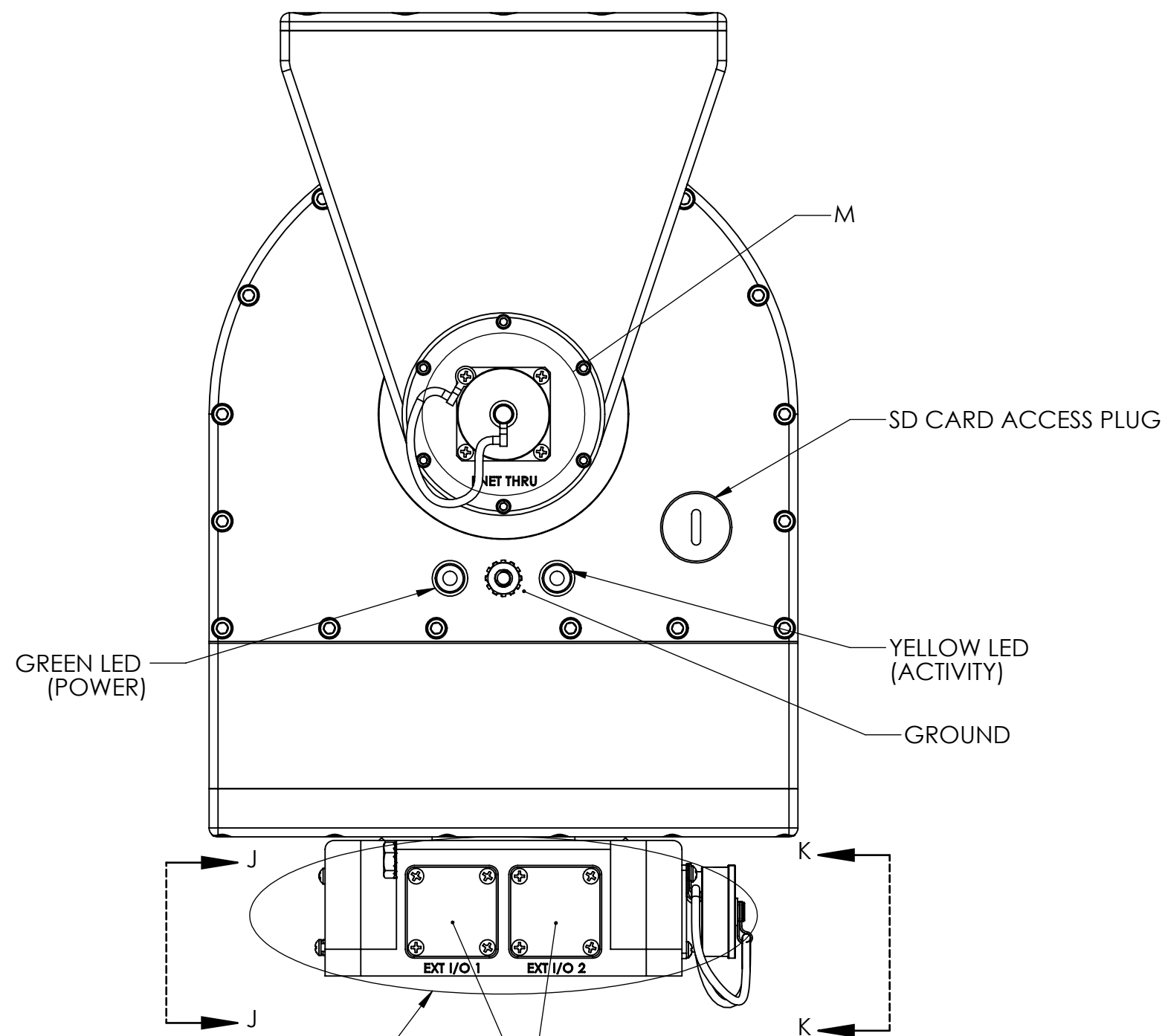

VIEW F-F
SCALE 1 : 2
SHEET 2
ZONE D-1

ALTERNATE
CONNECTOR
CONFIGURATION
SHEET 5
ZONE C-7

STANDARD CONFIGURATION - NO CONNECTORS

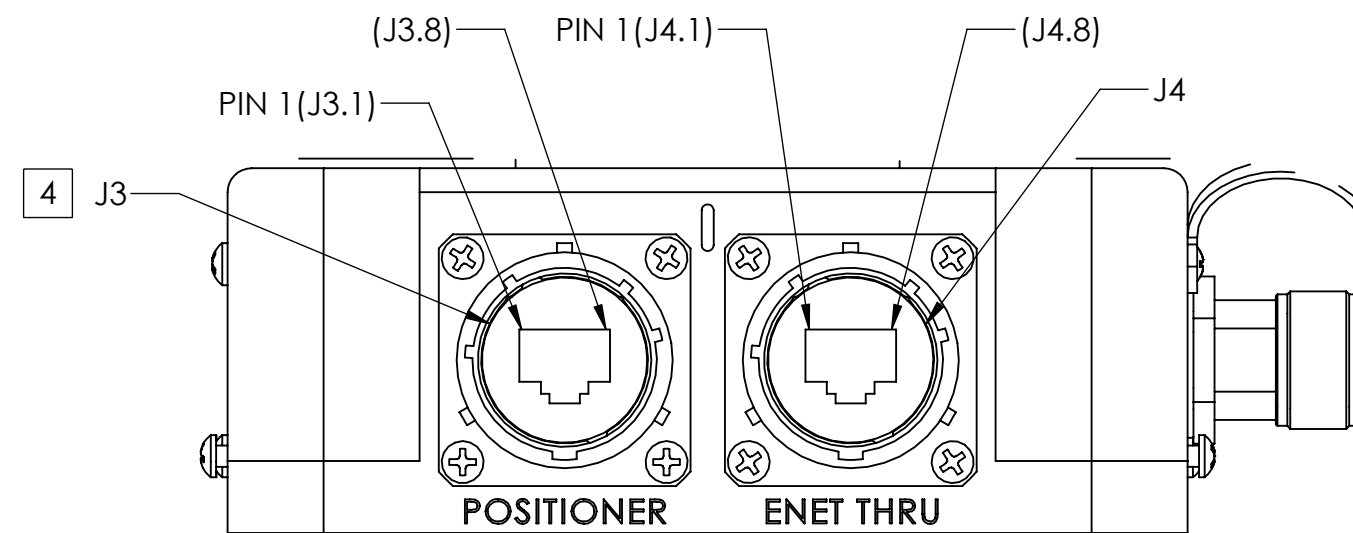

J3 & J4 CONNECTOR SHOWN FROM MATING SIDE
MATES WITH AMPHENOL P/N - RJF6B

VIEW K-K
SCALE 1 : 1
SHOWN WITHOUT PROTECTIVE CAPS
SEE TABLE III FOR J3 PINOUT DETAILS & TABLE V FOR J4 PINOUT DETAILS

TABLE III (PoE CONNECTOR)	
CONNECTOR DESIGNATION	FUNCTION
J3.1	DATA PAIR 1
J3.2	DATA PAIR 1
J3.3	DATA PAIR 2
J3.4	+50-57 VDC PoE POWER INPUT
J3.5	+50-57 VDC PoE POWER INPUT
J3.6	DATA PAIR 2
J3.7	DC RETURN FOR PoE INPUT
J3.8	DC RETURN FOR PoE INPUT

TABLE IV (AUX/POLARIZATION CONNECTOR)	
CONNECTOR DESIGNATION	FUNCTION
J6.1	GND
J6.2	+/-12 VDC MOTOR
J6.3	+/-12 VDC MOTOR
J6.4	POT WIPER
J6.5	+3.3V

TABLE V (PASS THRU CONNECTORS)	
FROM	TO
J1.1	J7.1
J2.1	J8.1
J4.1	J5.1
J4.8	J5.8

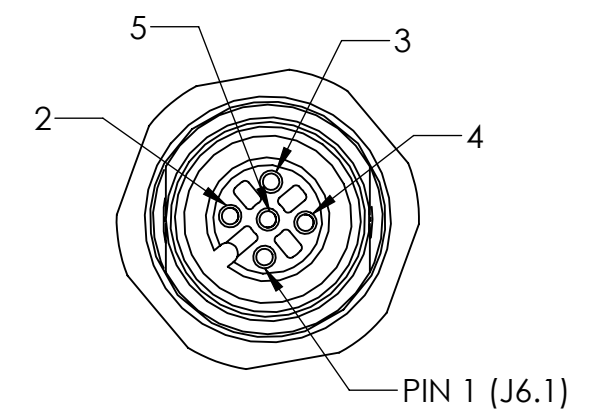

J6 CONNECTOR SHOWN FROM MATING SIDE
MATES WITH TURCK P/N RS 4.5-T-* (*LENGTH IN METERS)

DETAIL L
SCALE 2 : 1
SEE TABLE IV FOR PINOUT DETAILS

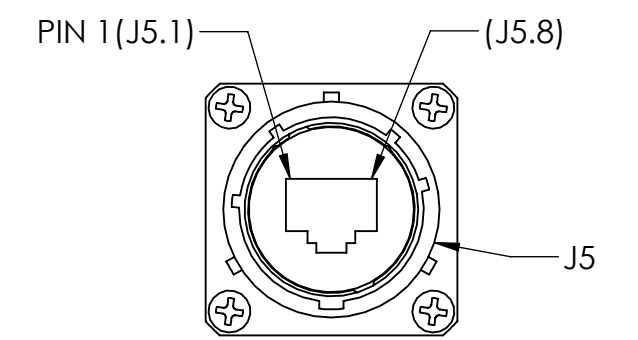

J5 CONNECTOR SHOWN FROM MATING SIDE
MATES WITH AMPHENOL P/N - RJF6B

DETAIL M
SCALE 1 : 1
SHOWN WITHOUT PROTECTIVE CAP
SEE TABLE V FOR PINOUT DETAILS

ALTERNATE CONNECTOR CONFIGURATIONS

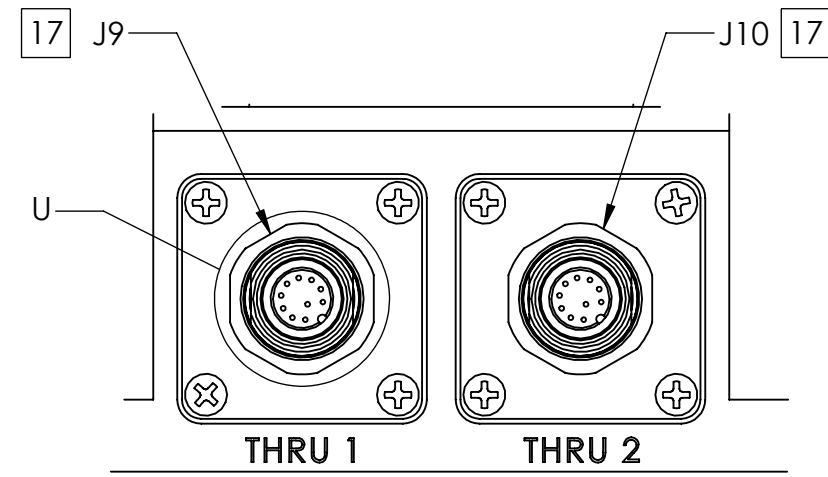

DETAIL N
SCALE 1 : 1
SHEET 2 ZONE A-6

SHOWN WITHOUT PROTECTIVE CAPS
SEE TABLE IX FOR FOR ALTERNATE CONNECTOR CONFIGURATIONS

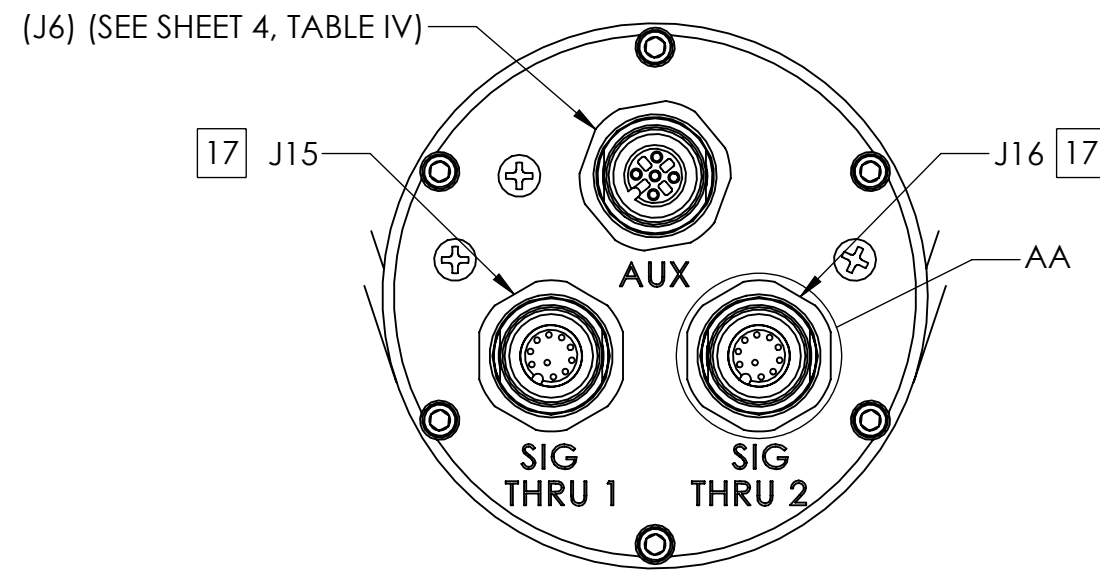

DETAIL T
SCALE 1 : 1
SHEET 2 ZONE C-6

SHOWN WITHOUT PROTECTIVE CAPS
SEE TABLE VII FOR FOR ALTERNATE CONNECTOR CONFIGURATIONS

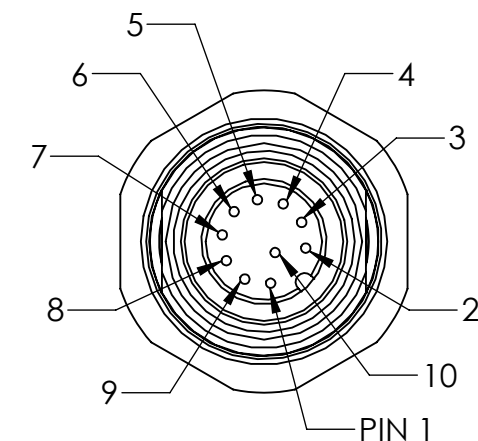

J9 & J10 CONNECTORS,
SHOWN FROM MATING SIDE,
MATES WITH TURCK
P/N RK 10-T-* (* LENGTH IN METERS)

DETAIL U
SCALE 2 : 1
2 PLACES
SEE TABLE VIII FOR
CONNECTOR PINOUT DETAILS

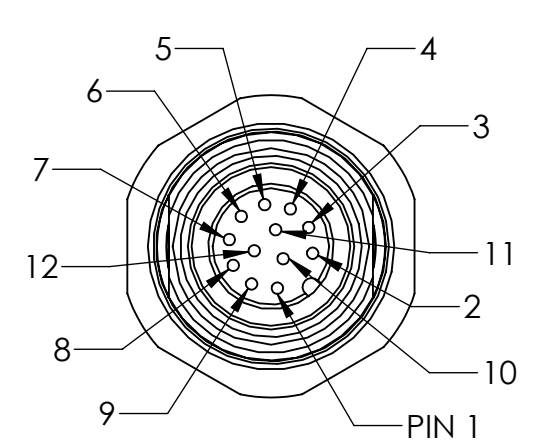

J11 & J12 CONNECTORS,
SHOWN FROM MATING SIDE,
MATES WITH TURCK
P/N RK 12-T-* (* LENGTH IN METERS)

DETAIL V
SCALE 2 : 1
2 PLACES
SEE TABLE VI FOR
CONNECTOR PINOUT DETAILS

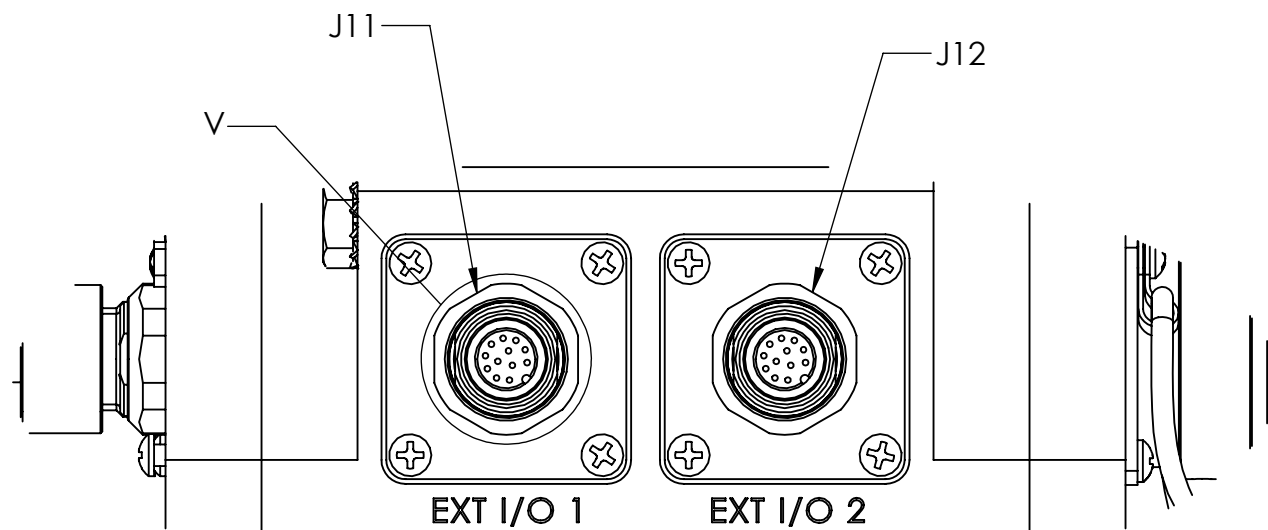

DETAIL P
SCALE 1 : 1
SHEET 4 ZONE A-8

SHOWN WITHOUT PROTECTIVE CAPS
SEE TABLE VI FOR FOR ALTERNATE CONNECTOR CONFIGURATIONS

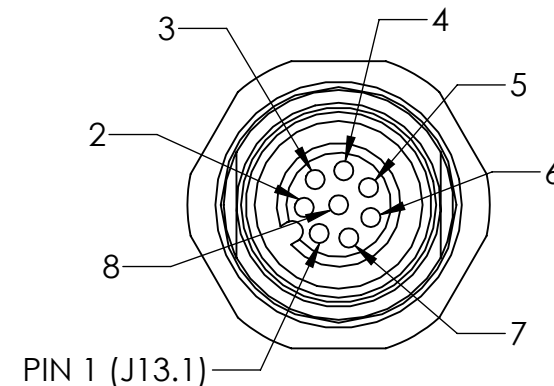

J13 CONNECTOR,
SHOWN FROM MATING SIDE,
MATES WITH TURCK
P/N RS 8-T-* (* LENGTH IN METERS)

DETAIL W
SCALE 2 : 1
SEE TABLE VII FOR
CONNECTOR PINOUT DETAILS

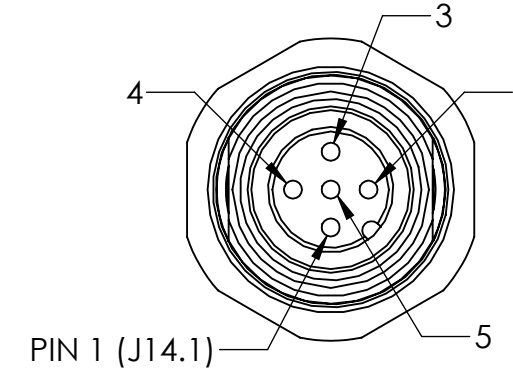

J14 CONNECTOR,
SHOWN FROM MATING SIDE,
MATES WITH TURCK
P/N RK 4.5-T-* (* LENGTH IN METERS)

DETAIL Y
SCALE 2 : 1
SEE TABLE VIII FOR
CONNECTOR PINOUT DETAILS

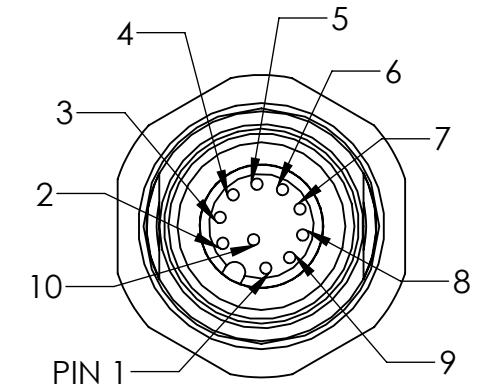

J15 & J16 CONNECTORS,
SHOWN FROM MATING SIDE,
MATES WITH TURCK
P/N RS 10T-* (* LENGTH IN METERS)

DETAIL AA
SCALE 2 : 1
2 PLACES
SEE TABLE IX FOR
CONNECTOR PINOUT DETAILS

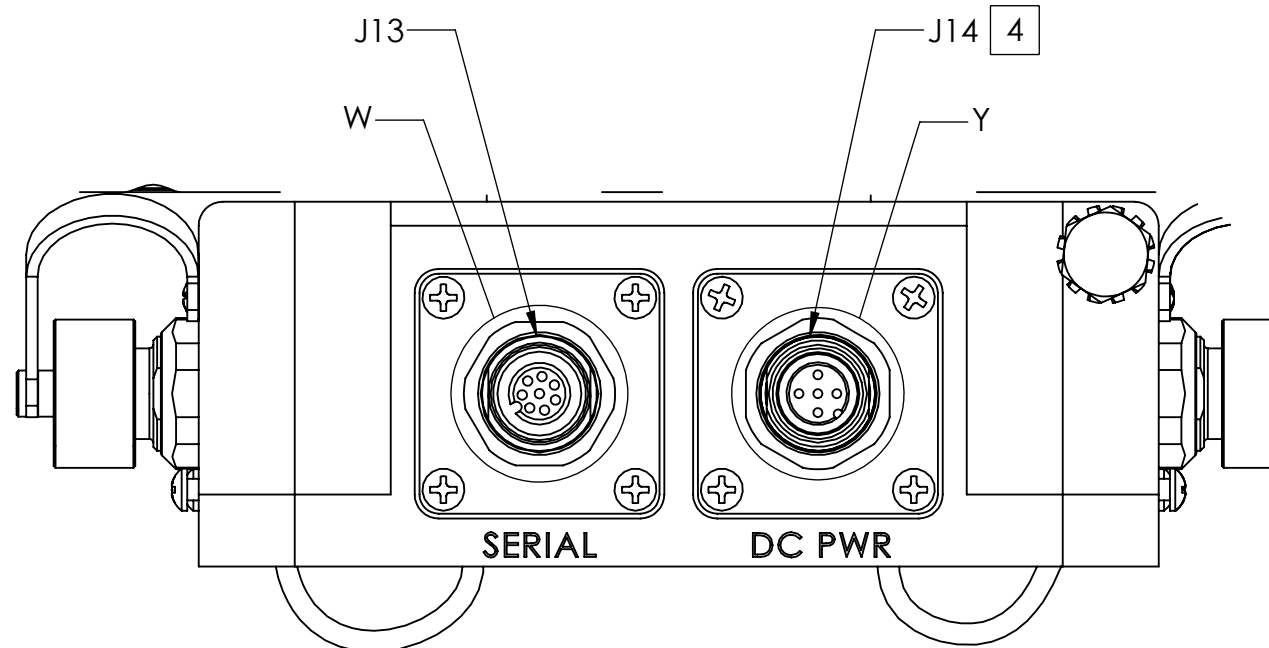

DETAIL R
SCALE 1 : 1
SHEET 4 ZONE E-2

SHOWN WITHOUT PROTECTIVE CAPS
SEE TABLE VII & VIII FOR FOR ALTERNATE CONNECTOR CONFIGURATIONS

TABLE VI (EXT I/O)

CONNECTOR DESIGNATION	FUNCTION
J11.1	ADC_1+
J11.2	GND
J11.3	IN2, IN_GPIO_1_27
J11.4	IN1, IN_GPIO_1_16
J11.5	COM
J11.6	IN3, IN_GPIO_1_24
J11.7	OUT1, OUT_GPIO_1_15
J11.8	OUT4, OUT_GPIO_1_22
J11.9	ADC_1-
J11.10	OUT3, OUT_GPIO_1_21
J11.11	IN4, IN_GPIO_1_14
J11.12	OUT2, OUT_GPIO_1_17
J12.1	ADC_2+
J12.2	GND
J12.3	IN6, IN_GPIO_0_6
J12.4	IN5, IN_GPIO_3_16
J12.5	COM
J12.6	IN7, IN_GPIO_1_26
J12.7	OUT5, OUT_GPIO_0_13
J12.8	OUT8, OUT_GPIO_1_28
J12.9	ADC_2-
J12.10	OUT7, OUT_GPIO_1_25
J12.11	IN 8, IN_GPIO_2_0
J12.12	OUT6, OUT_GPIO_3_21

TABLE VII (SERIAL CONNECTOR)

CONNECTOR DESIGNATION	FUNCTION
J13.1	5V
J13.2	GND
J13.3	12V
J13.4	GND
J13.5	RS232, UART4 Tx
J13.6	RS232, UART4 Rx
J13.7	RS232, UART5 Tx
J13.8	RS232, UART5 Rx

TABLE IX (PASS THRU CONNECTORS)

FROM	TO
J9.1	J15.1
↓	↓
J9.10	J15.10
J10.1	J16.1
↓	↓
J10.10	J16.10

TABLE VIII (POWER CONNECTOR)

CONNECTOR DESIGNATION	FUNCTION
J14.1	N/C
J14.2	N/C
J14.3	+20-60 VDC POWER INPUT
J14.4	N/C
J14.5	GND