

QLA-360EER-20

AUTO ACQUISITION ANTENNA POSITIONER FOR MICROWAVE LINE OF SIGHT

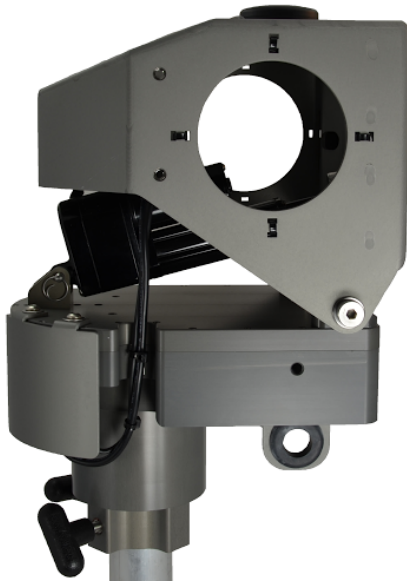

The QLA-360EER-20 is a Power Over Ethernet (PoE) antenna positioner designed from the ground up to automatically point and peak directional antennas for microwave line of sight communications.

The built in GPS and digital compass with full featured web based user interface provides rapid and accurate antenna pointing. The user interface includes a stored locations database that allows easy recall of known target locations followed by a final auto peak using radio signal strength.

The QLA-360EER-20 is typically paired with 2-3 ft antennas, payloads up to 90 lbs (40.8 kg), and offers 360° of azimuth and +/-20° of elevation range. Download the Interface Control Drawing (ICD) for more details.

Optional tri-pods, table top mount, radio adapter brackets, antenna adapter brackets, polarization rotators, joysticks, and transit cases are also available.

TECHNICAL SPECIFICATIONS – QLA-360EER-20

Power	Power Over Ethernet (POE) 48VDC-56VDC Supply Included
Material / Finish	Aluminum with stainless steel hardware / Hard coat anodize
Positioner Travel	
Azimuth	400° (+/-200°)
Elevation	40° (+/-20°)
Positioner Drive Rate	
Azimuth	Variable, up to 2.2°/sec no load
Elevation	Variable, up to 4°/sec no load
Temperature	
Operational	-22 to 140°F (-30 to 60°C)
Survival	-40 to 158°F (-40 to 70°C)
Feedback Resolution	0.1°
Backlash (Az / El)	less than 0.15° / less than 2°
Torque	
Operational (Az / El)	60 ft-lbs / 50 ft-lbs (81.3 Nm / 67.8 Nm)
Survival (Az / El)	200 ft-lbs / 75 ft-lbs (271.2 Nm / 101.7 Nm)
Payload	90 lbs (40.8 kg)
Dimensions	Height: 16.44" (41.8 cm), Width: 9.12" (23.2 cm), Depth: 11.23" (28.5 cm)
Weight	21.2 lbs (9.6 kg)
Mounting Interface	Clamps standard to a 2" dia mast (5 cm). Optional table top mount available
Antenna Mount Options	1/4-20 thumb nuts (tool-less) and 3/8-16 threaded holes (See ICD for details)
Communication Interface	
User Interfaces	Web based hosted internal to unit, Pelco D
Ethernet	10/100 Ethernet
Serial	RS-485

REV C

Specifications subject to change without notice

REV	DESCRIPTION	DATE	APPROVED
B	CN600564	2018-08-02	CLC

NOTES: UNLESS OTHERWISE SPECIFIED

1. QLA-360EER-20 CONFIGURABLE OPTIONS PER TABLE I. PART NUMBER LA-360EER-20-100 SHOWN THROUGHOUT THIS DRAWING. PoE CABLE SHOWN NOT TO SCALE
2. USE INTERFACE CONTROL DRAWING IN CONJUNCTION WITH DATASHEET N500125
3. 48-56VDC POWER SUPPLY INCLUDED WITH POSITIONER. NOT SHOWN IN DRAWING
4. HARD COAT ANODIZE ALUMINUM CONSTRUCTION WITH STAINLESS STEEL HARDWARE
5. 400° (+/-200°) AZIMUTH TRAVEL WITH 2.2°/SEC DRIVE RATE (NO LOAD)
6. 20° (+/-20°) ELEVATION TRAVEL WITH 4.0°/SEC DRIVE RATE (NO LOAD)
7. -22° TO 140°F (-30° TO 60°C) OPERATIONAL TEMPERATURE RANGE. -40 TO 158°F (-40 TO 70°C) NON-OPERATIONAL TEMPERATURE RANGE
8. 0.1° FEEDBACK RESOLUTION IN ALL AXES
9. AZIMUTH BACKLASH LESS THAN 0.15°. ELEVATION BACKLASH LESS THAN 2°
- 10 16.44" (41.8 cm) HIGH X 9.12" (23.2 cm) WIDE X 11.23" (28.5 cm) DEEP. DIMENSIONS APPLY WHEN POSITIONER IS AT 0° AZIMUTH AND 0° ELEVATION ANGLES
11. WEIGHT APPROXIMATELY 21.2 LBS (9.6 kg) NOT INCLUDING PoE CABLE
- 12 PAYLOAD SHALL NOT EXCEED 90 LBS OR 50 FT-LBS OF TORQUE ABOUT THE ELEVATION AXIS. TO CALCULATE TORQUE, TAKE THE DISTANCE FROM THE PAYLOAD CENTER OF GRAVITY TO DATUM -H- IN FEET AND MULTIPLY BY THE PAYLOAD WEIGHT. SEVERAL ANTENNA BRACKET OPTIONS AVAILABLE THAT INTERFACE DIRECTLY WITH FEATURES SHOWN. GO TO www.qparusa.com TO LEARN MORE
- 13 RADIO OR AUXILIARY EQUIPMENT MOUNTING FEATURES (BOTH SIDES). 10 LBS MAX
- 14 CENTER OF GRAVITY 0.2" (0.51 cm) IN THE X-DIRECTION, 7.1" (18.0 cm) IN THE Y-DIRECTION AND 1.8" (4.6 cm) IN THE Z-DIRECTION. X & Z MEASURED FROM THE CENTER OF THE 2.00" DIAMETER MOUNTING POLE
- 15 FOR PERMANENT INSTALLATIONS, IT IS RECOMMENDED THAT THE (2) INDICATED 5/16-18 THREADED KNOBS BE REPLACED WITH (2) 5/16-18 X 1.000" LONG STAINLESS STEEL HEX HEAD FASTENERS. HARDWARE PROVIDED WITH UNIT. TORQUE TO 132 IN-LBS
- 16 POSITIONER IS AT AZIMUTH PEDESTAL 0° WHEN INDICATED FASTENER IS AT POSITION SHOWN WITH CLAMPING KNOBS IN THE BACK AS SHOWN
- 17 POSITIONER CLAMPS TO STANDARD 2" OUTSIDE DIAMETER MAST (NOT INCLUDED). OPTIONAL MIDMOUNT KIT AVAILABLE TO ADAPT TO MAST DIAMETERS UP TO 6". GO TO www.qparusa.com TO LEARN MORE
- 18 5/16" QUICK RELEASE PIN TO SECURE POSITIONER TO MAST AND PREVENT ROTATION
- 19 MOUNTING HOLES FOR OPTIONAL COUNTER WEIGHT KIT, P/N - ACC-N900281-1

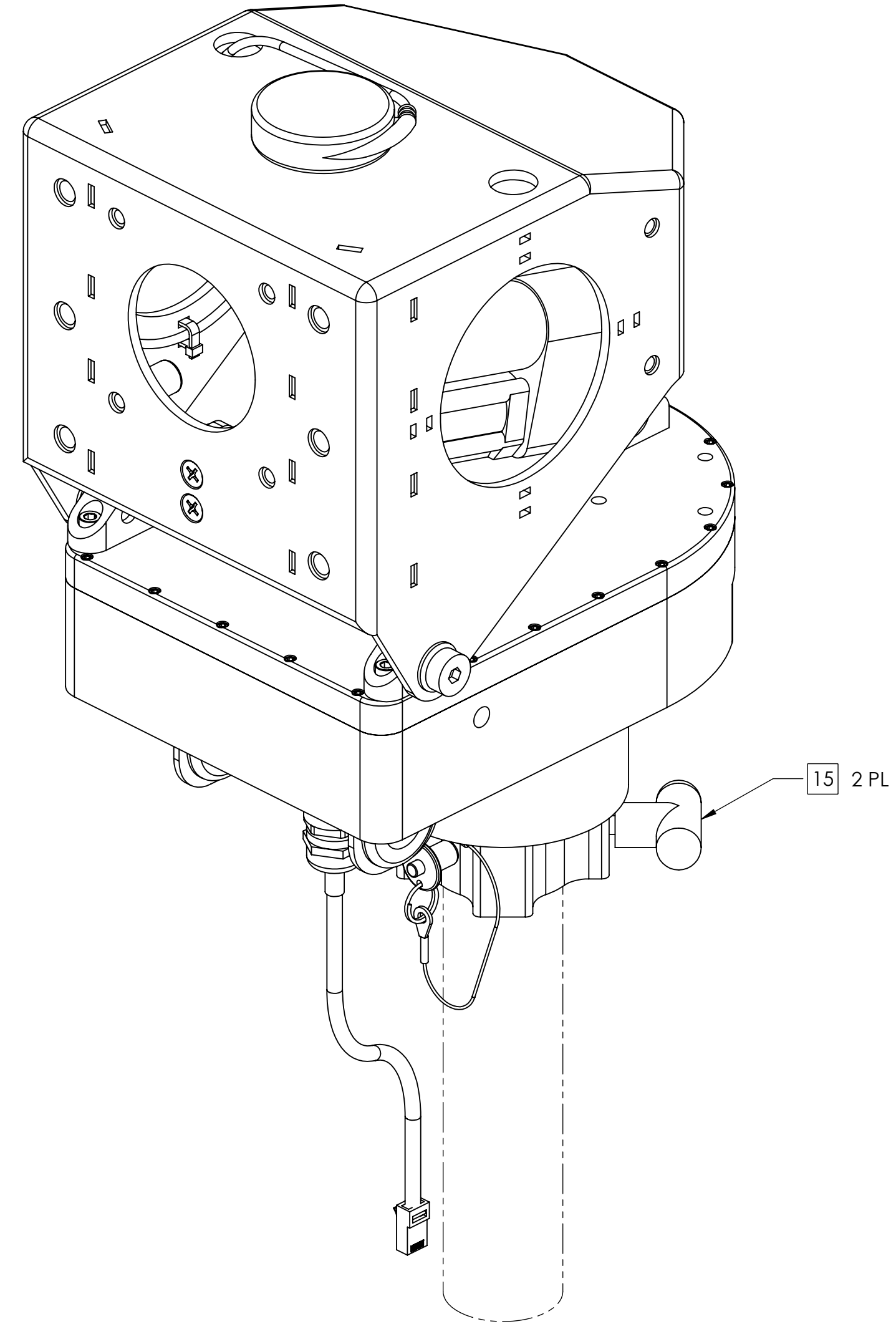
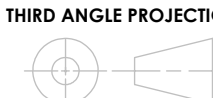
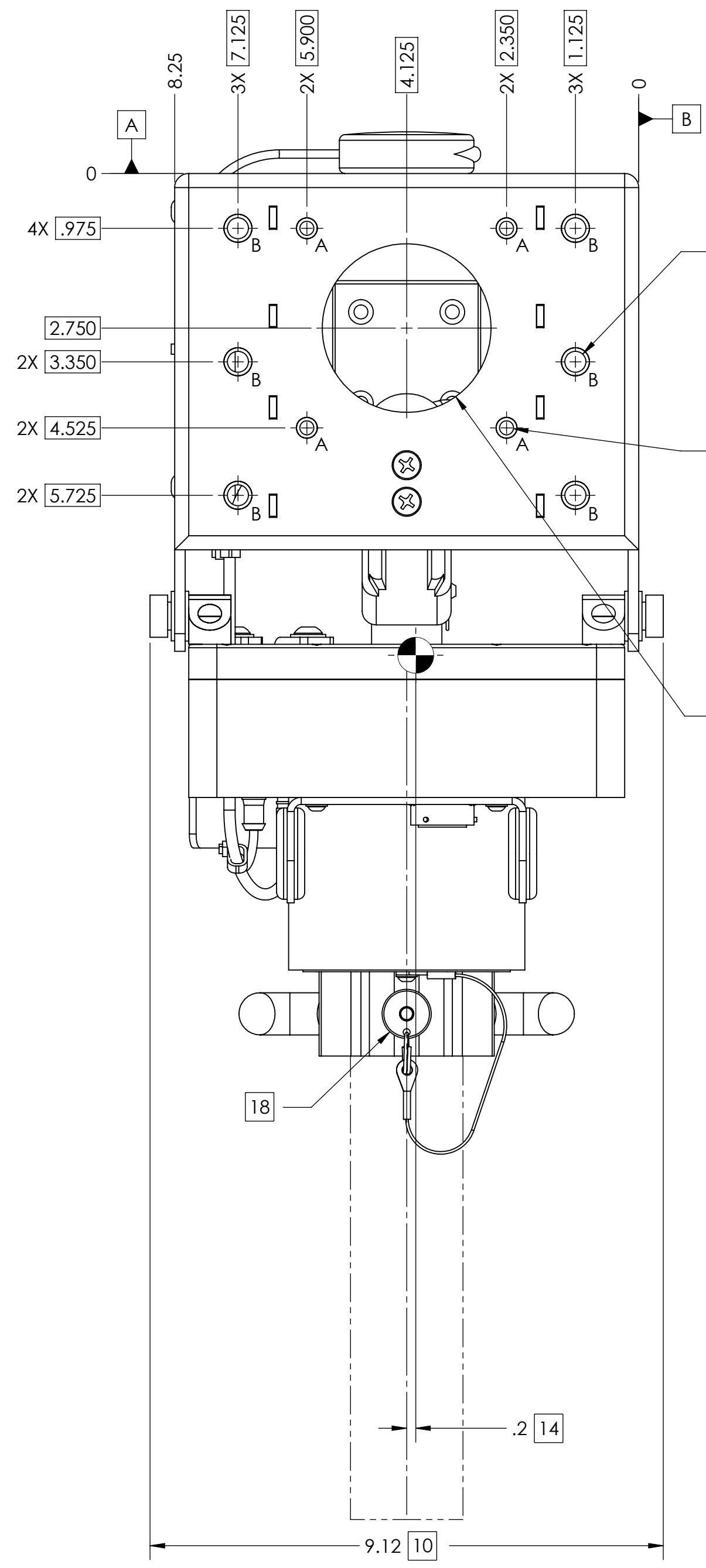

TABLE I	
BUILDING A PART NUMBER	STANDARD OPTIONS
LA-360EER - 20 - 100	<<EXAMPLE
	SHIELDED ETHERNET CABLE STANDARD LENGTHS
	050 = 50 ft
	100 = 100 ft
	150 = 150 ft
	200 = 200 ft
	250 = 250 ft
	300 = 300 ft
	XXX = Custom length in feet
	XXXC = Add "C" to end of cable length for unterminated mating connector
	CUSTOM CONFIGURATION
	= Standard options - leave blank
	MOTOR DRIVES AND PAYLOAD
	20 = Az 60 ft-lbs @ 2.2°/s, El 50 ft-lbs @ 2°/s, 90 lb payload. Typically paired with 2-3 ft antenna (+/-220° azimuth, +/-20° elevation)
	MODEL
	LA-360EER = LinkAlign-360EER (See motor drives and payload section for positioner travel range info)

SYMBOL KEY □ NOTE ○ PL ITEMS PROPRIETARY AND CONFIDENTIAL THE INFORMATION CONTAINED IN THIS DRAWING IS THE SOLE PROPERTY OF QPARUSA. ANY REPRODUCTION IN PART OR AS A WHOLE WITHOUT THE WRITTEN PERMISSION OF QPARUSA IS PROHIBITED. QPAR ANTENNAS USA, LLC LAS VEGAS, NV 89121 www.qparusa.com	UNLESS OTHERWISE SPECIFIED: DIMENSIONS ARE IN INCHES TOLERANCES: ANGLE ± 5 DEGREES TWO PLACE DECIMAL ±.030 THREE PLACE DECIMAL ±.010 INTERPRET DIM AND TOL PER ASME Y14.5M - 1994 THIRD ANGLE PROJECTION  DO NOT SCALE DRAWING	DRAWN S. CHEYNE 2015-01-07 CHECKED C. CHEYNE 2018-08-02 ME APPR. S. CHEYNE 2015-01-07 EE APPR.	QPAR Antennas USA, LLC TITLE: QLA-360EER-20 INTERFACE CONTROL DRAWING
		PART NO. SEE TABLE I	SIZE DWG. NO. REV C ICDN900356 B

8 7 6 5 4 3 2 1

F
E
D
C
B
A



6X .375-16 UNC-2B
CAPTIVE NUTS INSTALLED
FROM FAR SIDE
HOLES MARKED B
 $\oplus \phi .030$ A B C
MINOR DIAMETER

4X .250-20 UNC-2B
CAPTIVE THUMB NUTS
 $\nabla .500 - \nabla .750$ THREAD DEPTH
HOLES MARKED A
 $\oplus \phi .020$ A B C
MINOR DIAMETER

$\phi 3.000 \pm .050$ THRU
 $\oplus \phi .020$ A B C

ANTENNA MOUNTING FEATURES

12

4 3 2 1

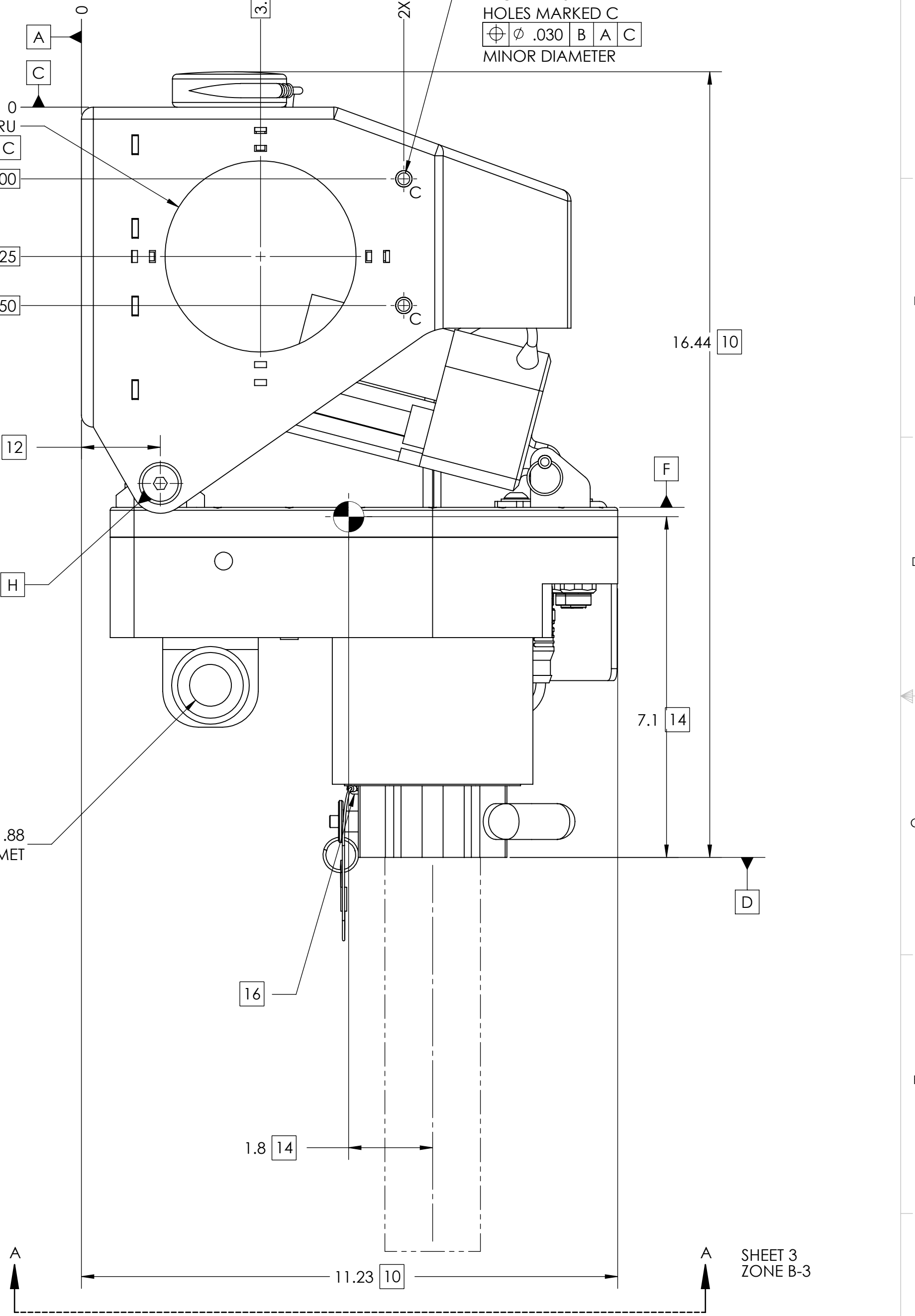

2X .250-20 UNC-2B
CAPTIVE NUTS INSTALLED
FROM FAR SIDE
HOLES MARKED C
 $\oplus \phi .030$ B A C
MINOR DIAMETER

$\phi 4.000 \pm .050$ THRU
 $\oplus \phi .020$ B A C

2X $\phi .88$
RUBBER GROMMET

RADIO OR AUXILIARY EQUIPMENT MOUNTING FEATURES

13

8 7 6 5 4 3 2 1

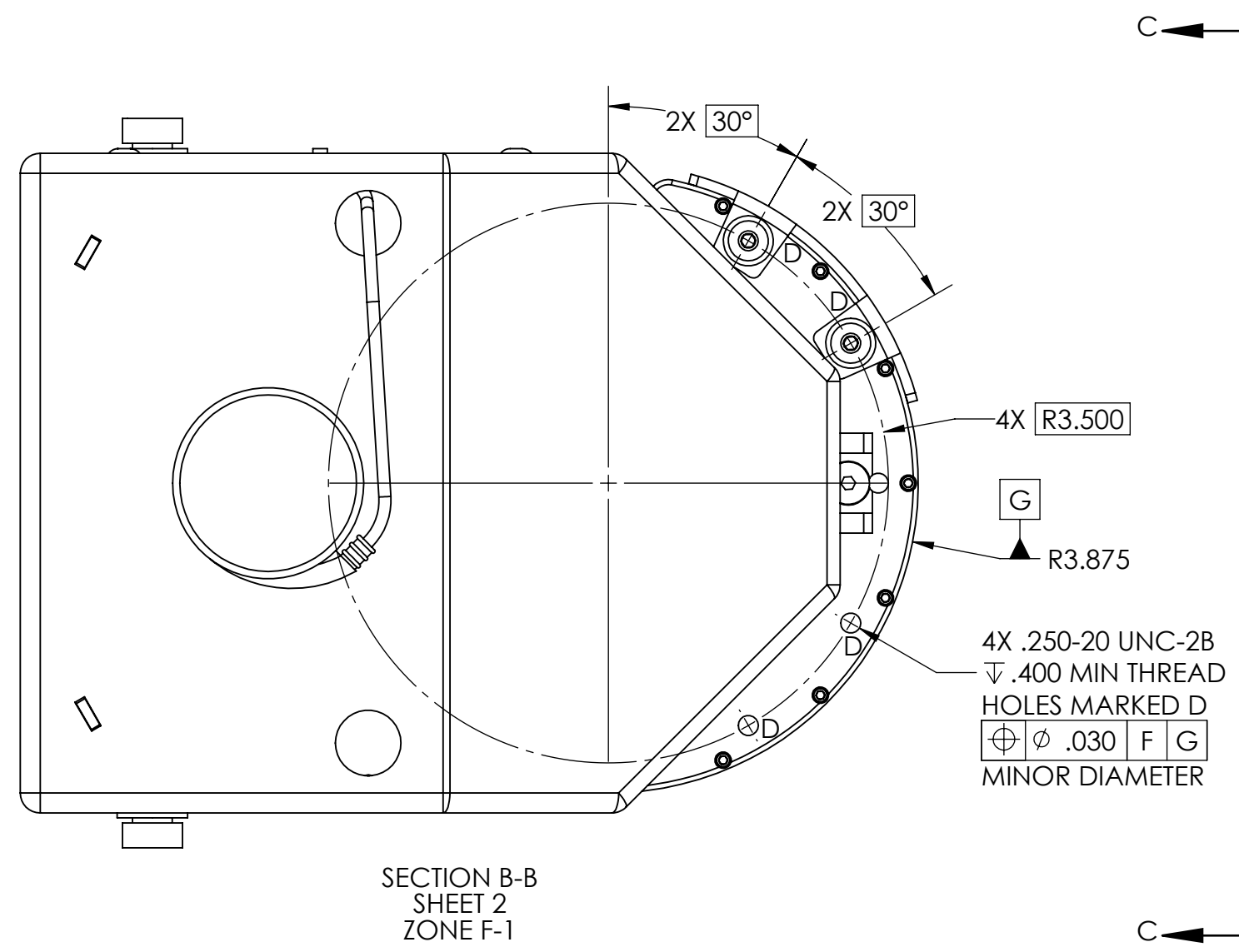

SECTION B-B
SHEET 2
ZONE F-1

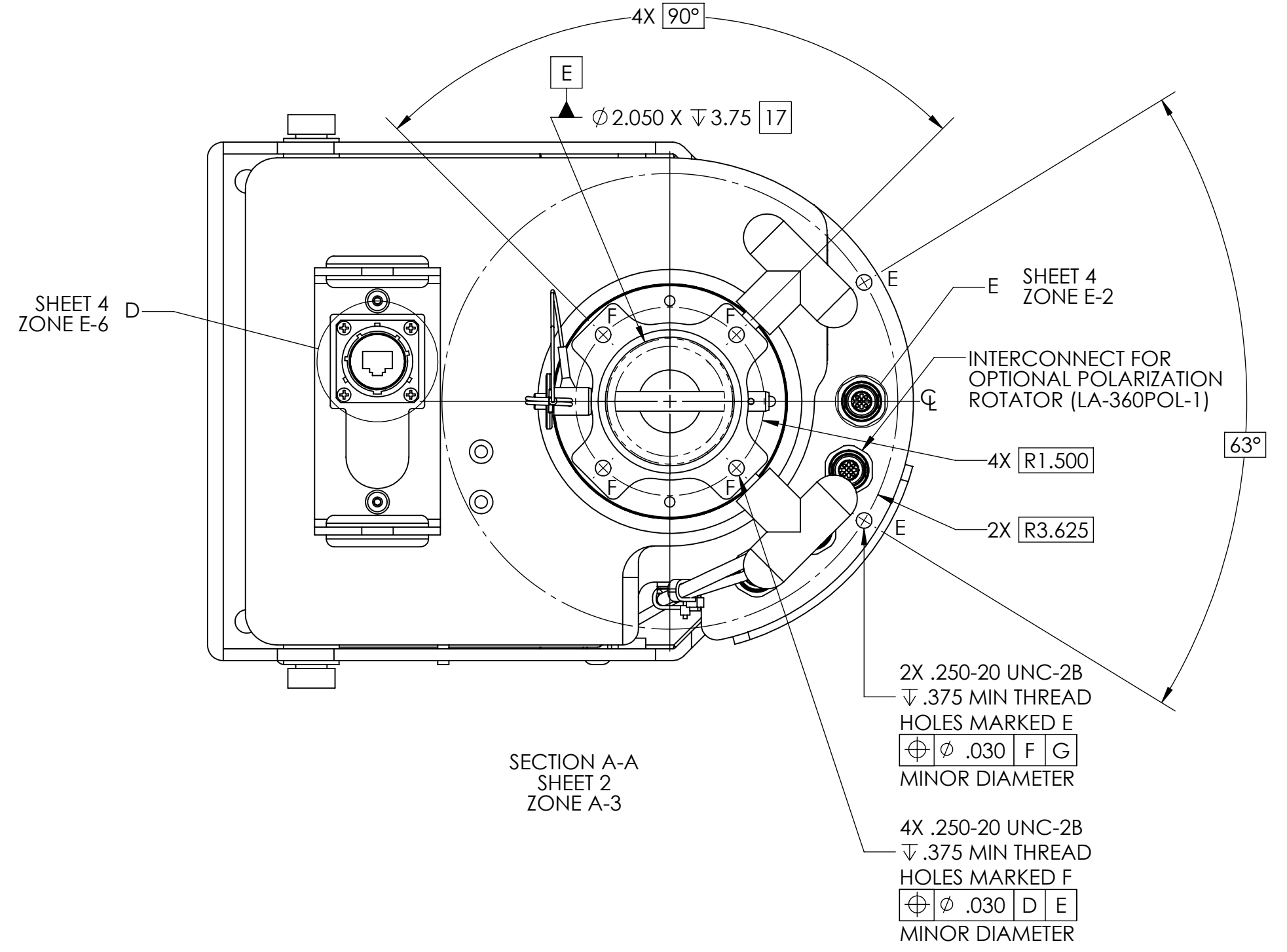

SECTION A-A
SHEET 2
ZONE A-3

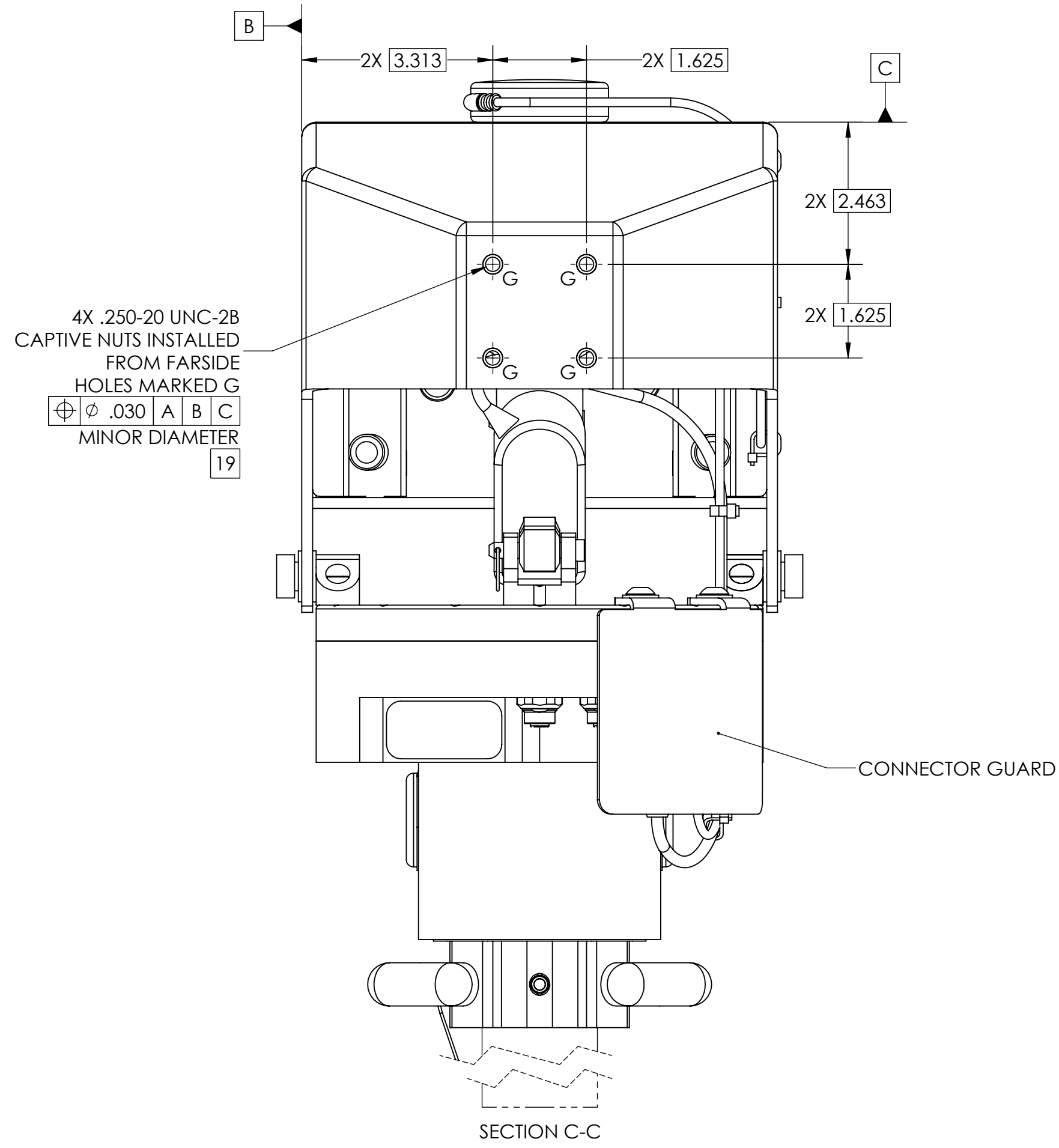

SECTION C-C

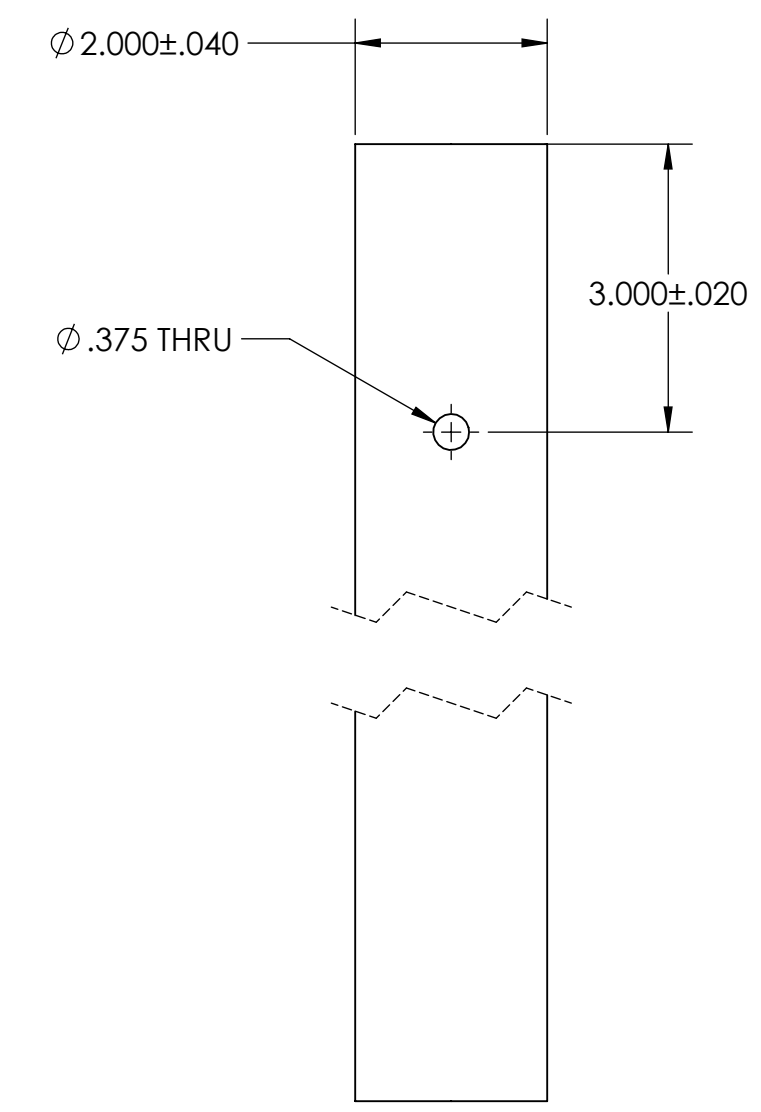

SUGGESTED POSITIONER
MAST DIMENSIONS

17

INTERCONNECT FOR POSITIONER PoE

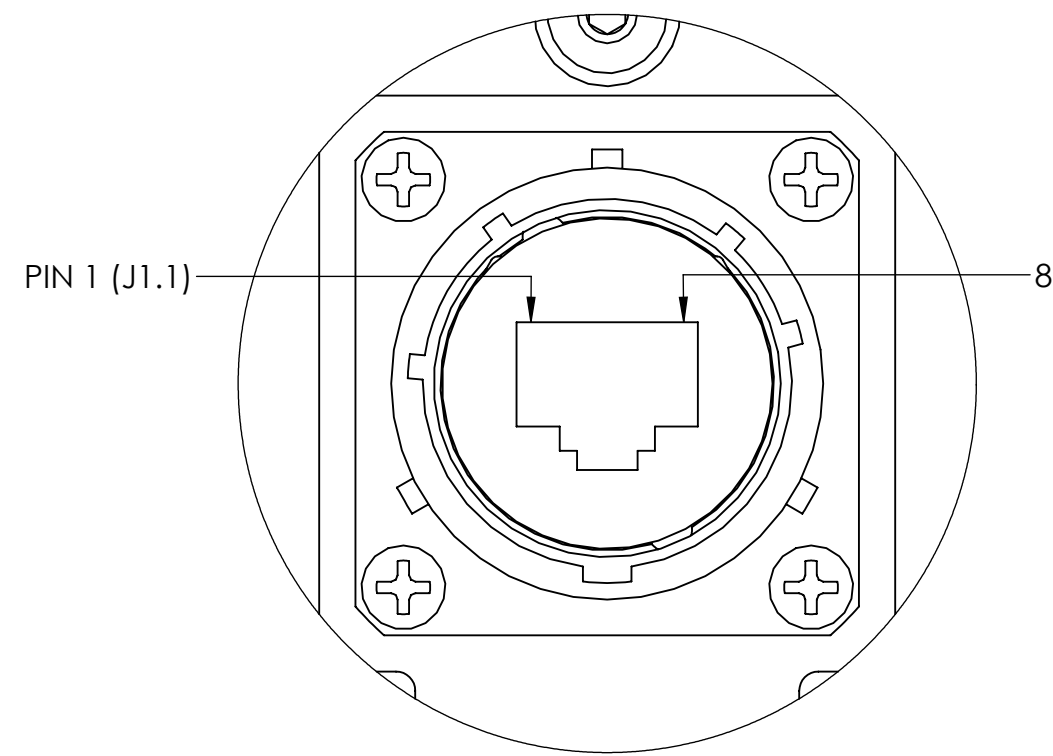

J1 CONNECTOR SHOWN FROM MATING SIDE
MATES WITH AMPHENOL P/N - RJF6B

DETAIL D
SCALE 2 : 1
SHEET 3
ZONE E-3
SEE TABLE II FOR PINOUT DETAILS

TABLE II (PoE CONNECTOR)	
CONNECTOR DESIGNATION	FUNCTION
J1.1	DATA PAIR 1
J1.2	DATA PAIR 1
J1.3	DATA PAIR 2
J1.4	+48-56VDC PoE POWER INPUT
J1.5	+48-56VDC PoE POWER INPUT
J1.6	DATA PAIR 2
J1.7	DC RETURN FOR PoE INPUT
J1.8	DC RETURN FOR PoE INPUT

INTERCONNECT FOR SERIAL INTERFACE

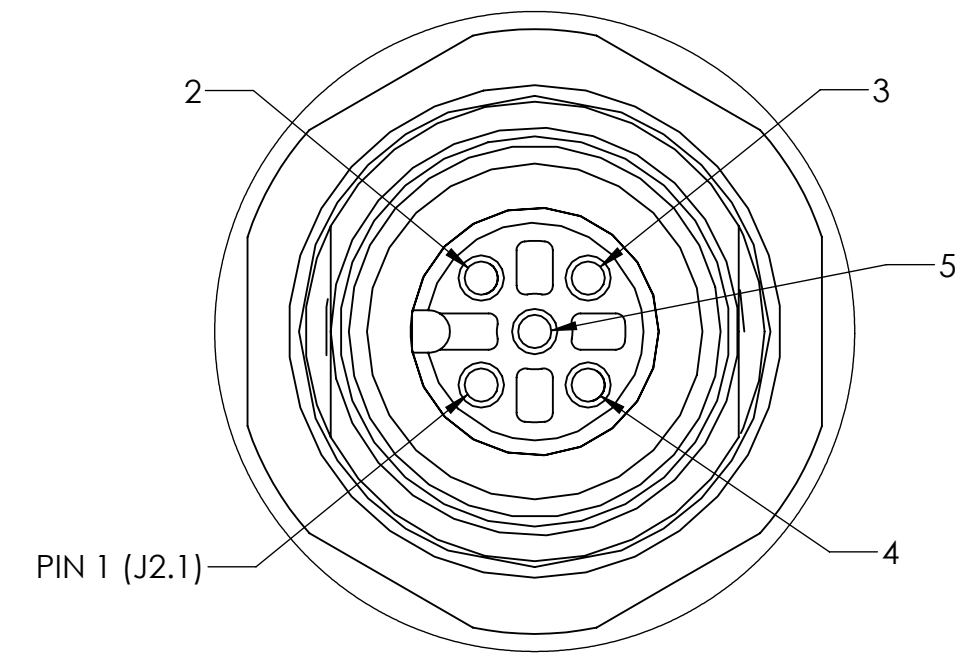

J2 CONNECTOR SHOWN FROM MATING SIDE
MATES WITH TURCK P/N - 8151-0/PG9

DETAIL E
SCALE 4 : 1
SHEET 3
ZONE E-2
SEE TABLE III FOR PINOUT DETAILS

TABLE III (SERIAL CONNECTOR)	
CONNECTOR DESIGNATION	FUNCTION
J2.1	DC RETURN FOR QPARUSA JOYSTICK
J2.2	NOT USED
J2.3	(B) TxD-/RxD- DATA LINE
J2.4	(A) TxD+/RxD+ DATA LINE
J2.5	DC POWER FOR QPARUSA JOYSTICK